

# Chaos, Complexity & Christianity

## ***1. Presentation: the faith of a hydrologist***

Carlos E. Puente

*University of California, Davis*

Welcome to  
**Chaos, Complexity & Christianity**

*An original class from Science to Faith*

*To reconcile the world in **Jesus Christ**,  
for only his love is the solution...*

# Summary

- *It shares the story of my conversion based on science.*
- *Introduces the theme of the other encounters of the class.*

# **An improbable story**

*(Puente 2020a)*

# My grandparents



*Don Julito & Mama Fanny*

# My grandparents



*Don Julito & Mama Fanny*

*Dora*, my mom, their only daughter

# My grandparents



*Don Julito & Mama Fanny*

*Dora*, my mom, their only daughter

***Mama Fanny***, my best example of faith

# A beautiful wedding

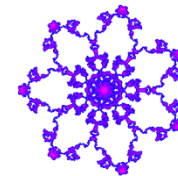

lovely bridal bouquets by **Mama Fanny**



# A little bit about me



I was born in *Cartagena*, Colombia

# A little bit about me



I was born in *Cartagena*, Colombia

I received my *first communion* when I was 8

# A little bit about me

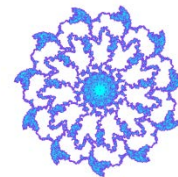

I was born in *Cartagena, Colombia*

I received my *first communion* when I was 8

but, my family, in general, did not practice their religion...

# My days at the university



I entered *Universidad de los Andes*, in Bogotá, when I was 16

# My days at the university



I entered *Universidad de los Andes*, in Bogotá, when I was 16

I studied **Mathematics** and **Civil Engineering**

# My days at the university



I entered *Universidad de los Andes*, in Bogotá, when I was 16

I studied *Mathematics* and *Civil Engineering*

once at the university, I stopped going to **Mass**

# My days at the university

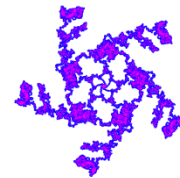

I entered *Universidad de los Andes*, in Bogotá, when I was 16

I studied *Mathematics* and *Civil Engineering*  
once at the university, I stopped going to **Mass**

I believed in a creator **God**

but not in one that would care for me personally

# My graduate studies at MIT

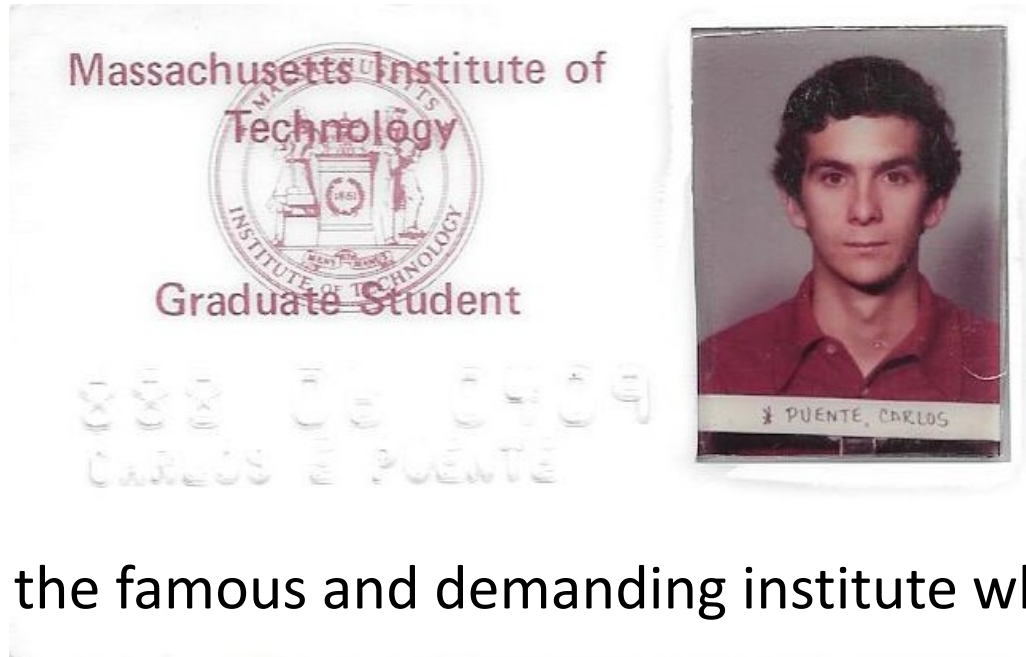

I arrived to the famous and demanding institute when I was 24



# My graduate studies at MIT

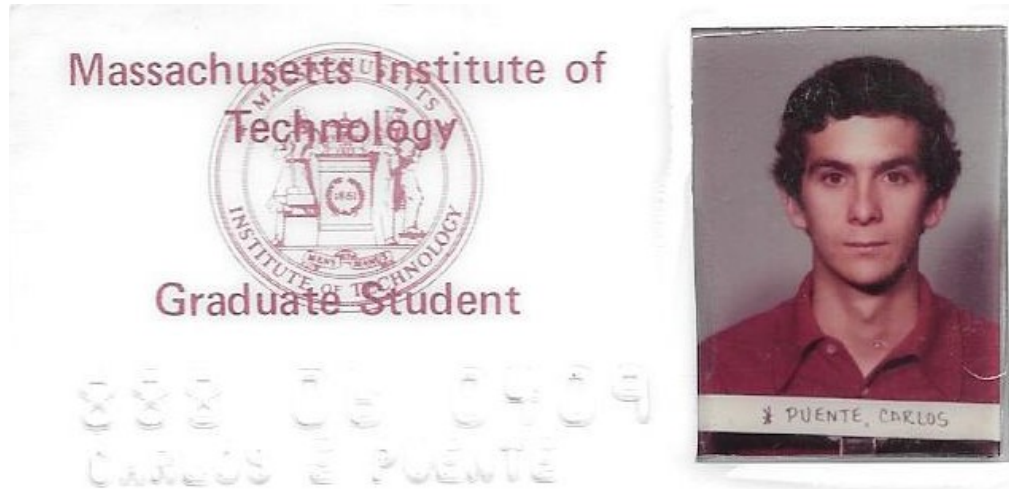

I arrived to the famous and demanding institute when I was 24  
I married my Colombian girlfriend when I was 25

# My graduate studies at MIT

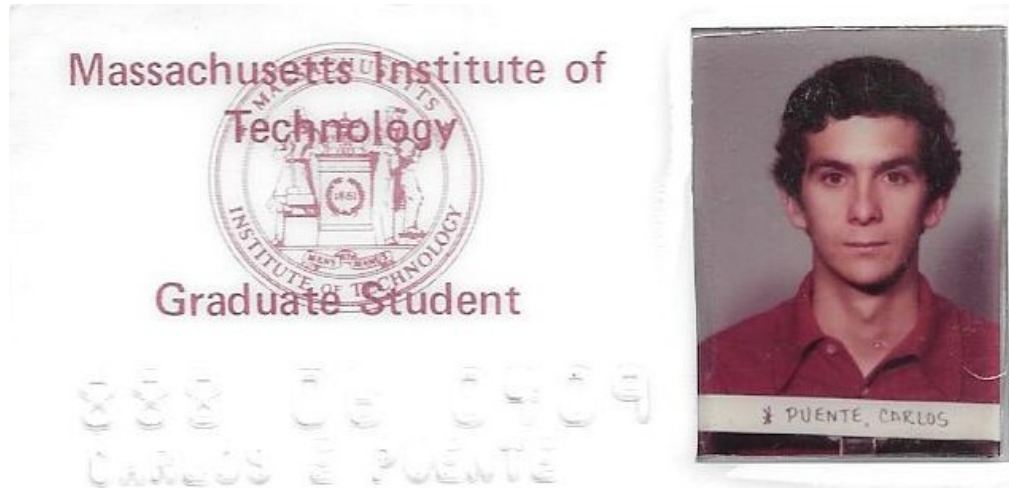

I arrived to the famous and demanding institute when I was 24

I married my Colombian girlfriend when I was 25

I got Masters in **Operations Research** and **Civil Engineering**  
and my PhD in **Hydrology**, the science of water, when I was 28

# My graduate studies at MIT

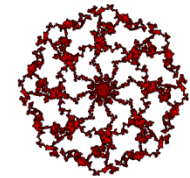

I arrived to the famous and demanding institute when I was 24

I married my Colombian girlfriend when I was 25

I got Masters in *Operations Research* and *Civil Engineering*  
and my PhD in *Hydrology*, the science of water, when I was 28

...sometimes I would go to **Mass** at Boston University

# As a newcomer to UC Davis

*(Barnsley, 1988)*

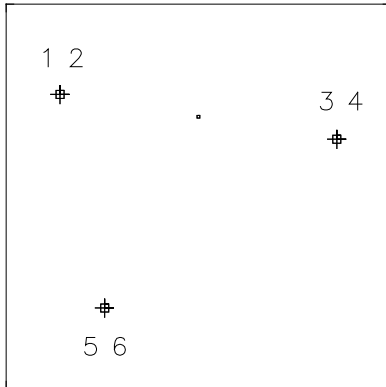

# As a newcomer to UC Davis

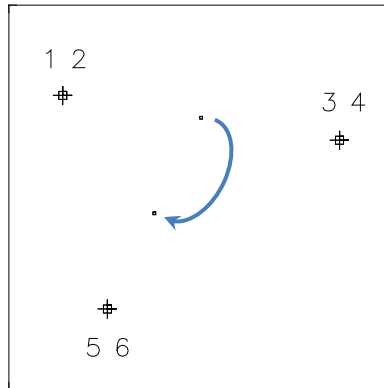
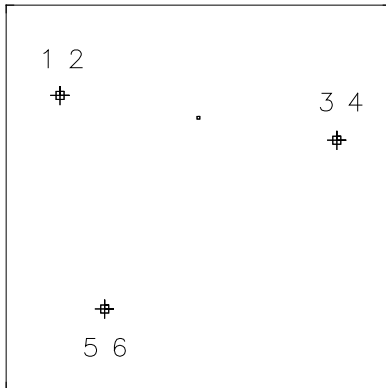

# As a newcomer to UC Davis

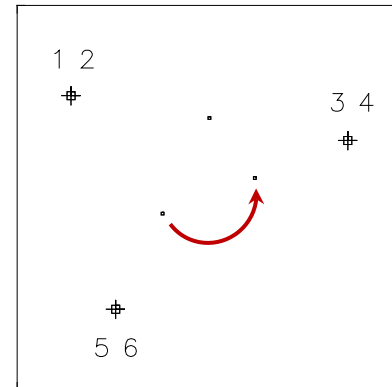
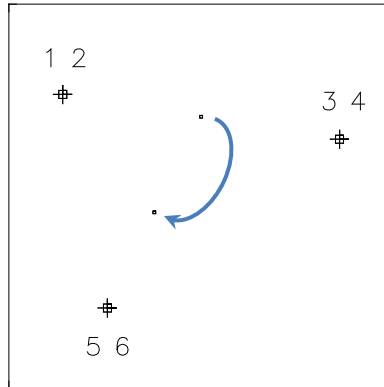
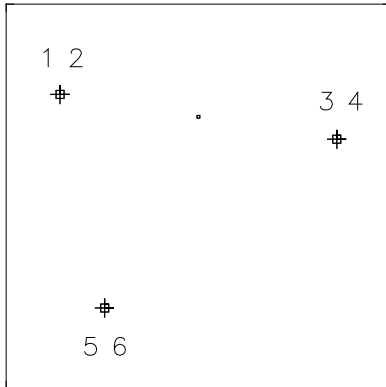

# As a newcomer to UC Davis

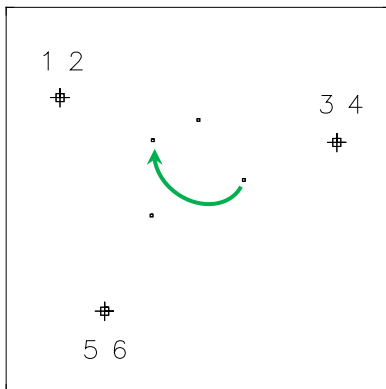
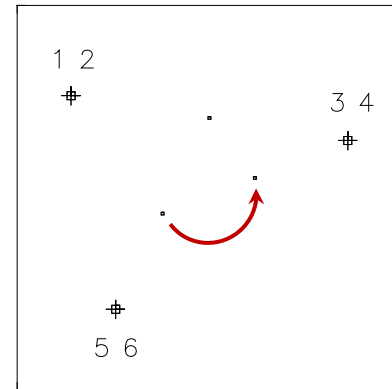
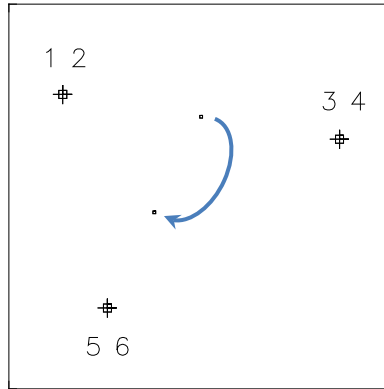
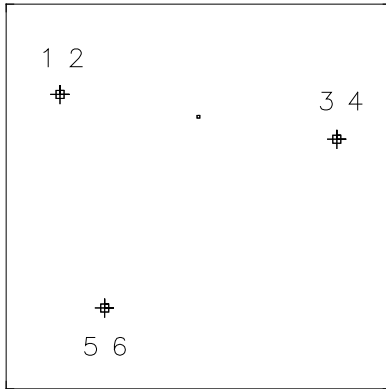

# As a newcomer to UC Davis

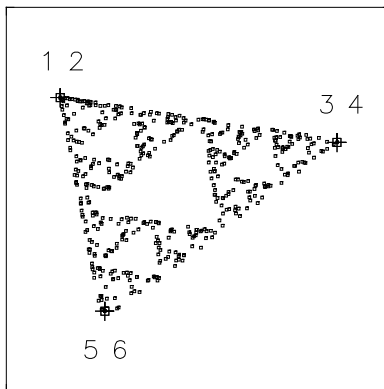
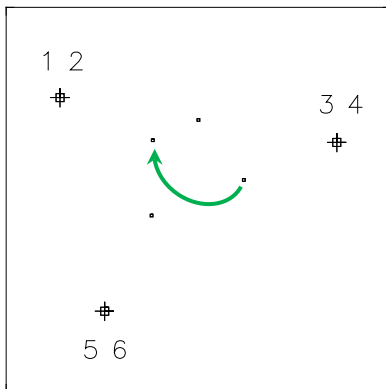
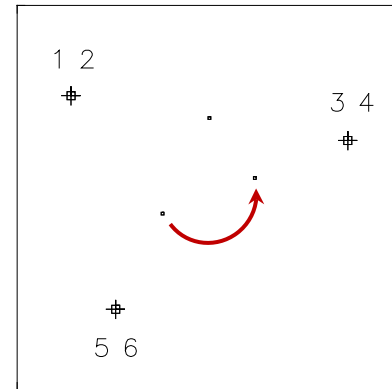
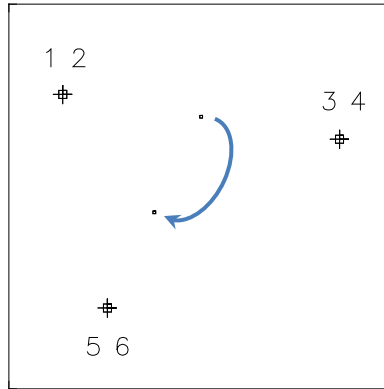
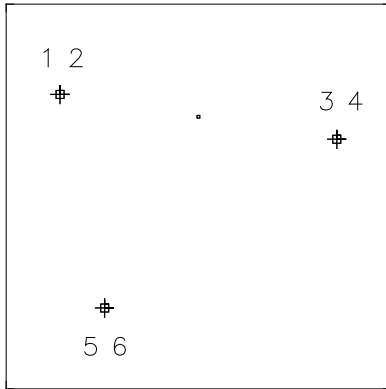



# As a newcomer to UC Davis

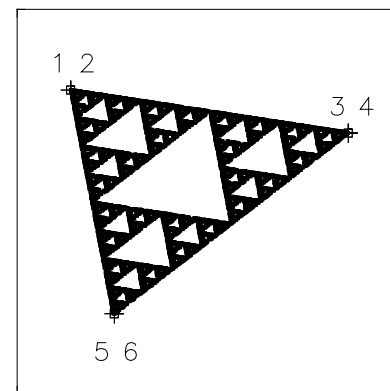
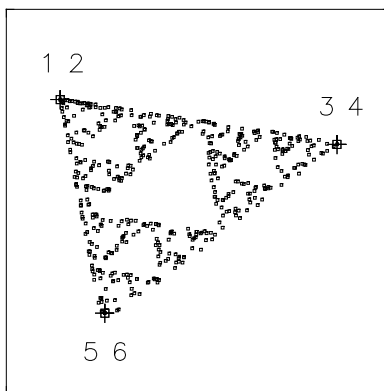
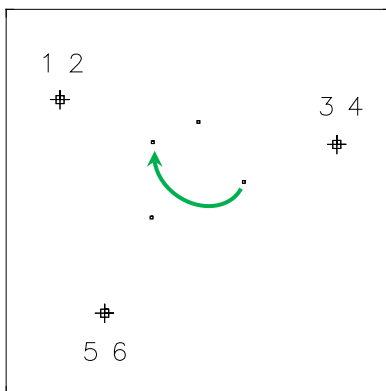
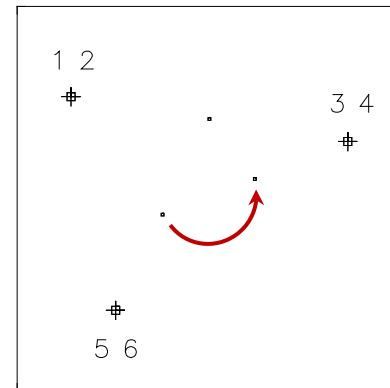
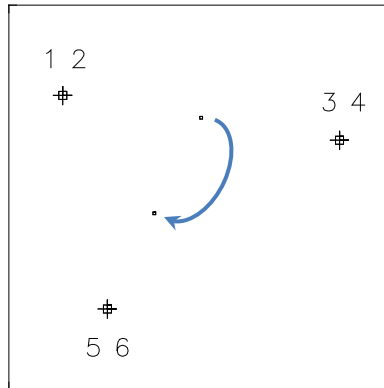
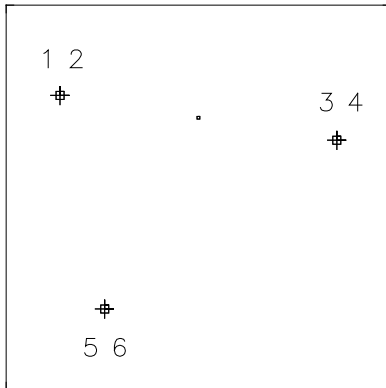

**fractal Sierpinski (!)**

# Changing the rules

*(Barnsley, 1988)*

$$w_1(x, y) = \left( \frac{x}{2}, x + d_1 \cdot y \right), w_2(x, y) = \left( \frac{x}{2} + \frac{1}{2}, 1 - x + d_2 \cdot y \right)$$

# Changing the rules

$$w_1(x, y) = \left( \frac{x}{2}, x + d_1 \cdot y \right), w_2(x, y) = \left( \frac{x}{2} + \frac{1}{2}, 1 - x + d_2 \cdot y \right)$$

simple rules from the *plane* to the *plane*

# Changing the rules

$$w_1(x, y) = \left( \frac{x}{2}, x + d_1 \cdot y \right), w_2(x, y) = \left( \frac{x}{2} + \frac{1}{2}, 1 - x + d_2 \cdot y \right)$$

simple rules from the *plane* to the *plane*

the  $x$  component is *decoupled* from  $y$

# Changing the rules

$$w_1(x, y) = \left( \frac{x}{2}, x + d_1 \cdot y \right), w_2(x, y) = \left( \frac{x}{2} + \frac{1}{2}, 1 - x + d_2 \cdot y \right)$$

simple rules from the *plane* to the *plane*

the  $x$  component is *decoupled* from  $y$

the  $y$  component is a *linear* combination of  $x$  and  $y$

# Changing the rules

$$w_1(x, y) = \left( \frac{x}{2}, x + d_1 \cdot y \right), w_2(x, y) = \left( \frac{x}{2} + \frac{1}{2}, 1 - x + d_2 \cdot y \right)$$

simple rules from the *plane* to the *plane*

the  $x$  component is *decoupled* from  $y$

the  $y$  component is a *linear* combination of  $x$  and  $y$

$d_1$  and  $d_2$  are **parameters** with **magnitudes** less than 1

# Changing the rules

$$w_1(x, y) = \left( \frac{x}{2}, x + d_1 \cdot y \right), w_2(x, y) = \left( \frac{x}{2} + \frac{1}{2}, 1 - x + d_2 \cdot y \right)$$

simple rules from the *plane* to the *plane*

the  $x$  component is *decoupled* from  $y$



the  $y$  component is a *linear* combination of  $x$  and  $y$

$d_1$  and  $d_2$  are **parameters** with **magnitudes** less than 1

the rules pass by  $\{(0,0), (0.5,1) (1,0)\}$

# Changing the rules

$$w_1(x, y) = \left( \frac{x}{2}, x + d_1 \cdot y \right), \quad w_2(x, y) = \left( \frac{x}{2} + \frac{1}{2}, 1 - x + d_2 \cdot y \right)$$

simple rules from the *plane* to the *plane*

the  $x$  component is *decoupled* from  $y$

the  $y$  component is a *linear* combination of  $x$  and  $y$

$d_1$  and  $d_2$  are **parameters** with **magnitudes** less than 1

the rules pass by  $\{(0,0), (0.5,1), (1,0)\}$

$$x \in [0, 1]$$

$w_1$  operates to the **left** and  $w_2$  to the **right**



# Tossing a coin...

$\{(0,0), (0.5,1), (1,0)\}$

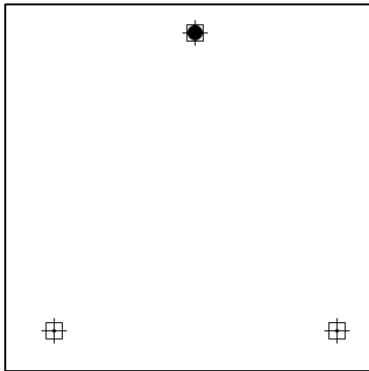

# Tossing a coin...

$$d_1 = -d_2 = z = 0.5$$

←  $w_1$        $w_2$  →

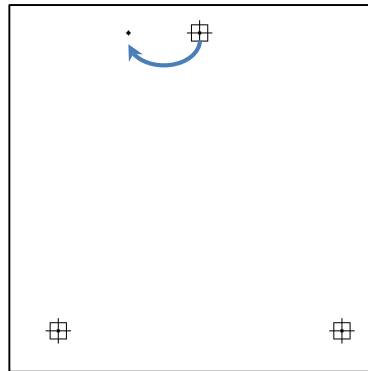
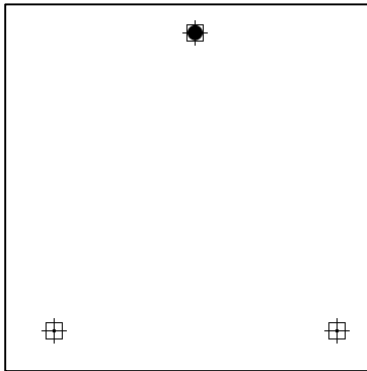

# Tossing a coin...

$$d_1 = -d_2 = z = 0.5$$

←  $w_1$        $w_2$  →

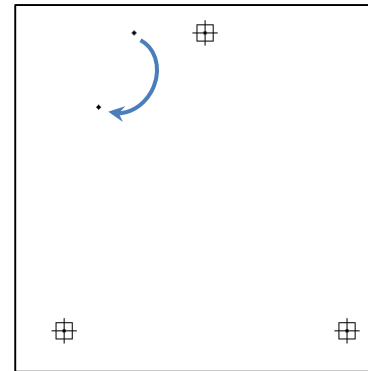
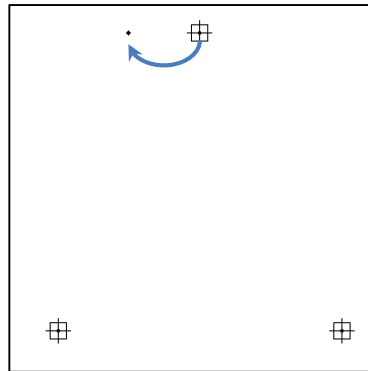
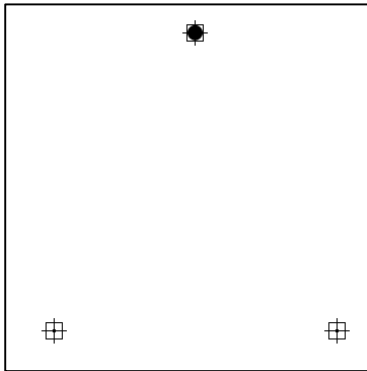

# Tossing a coin...

$$d_1 = -d_2 = z = 0.5$$

←  $w_1$        $w_2$  →

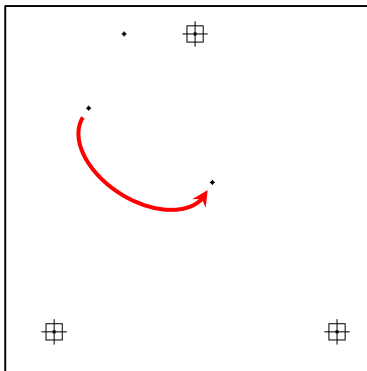
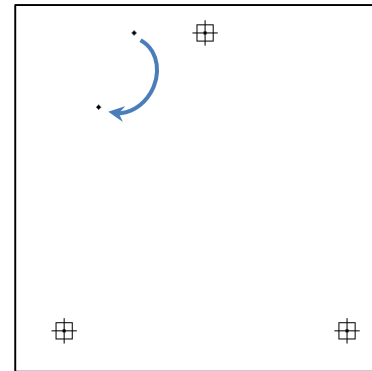
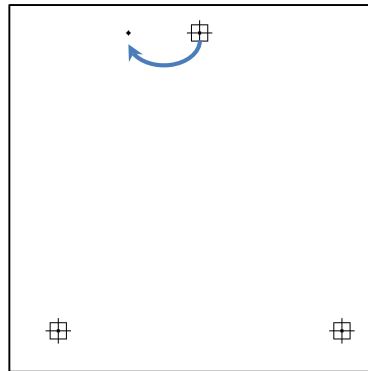
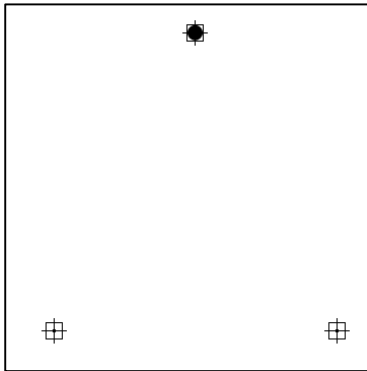

# Tossing a coin...

$$d_1 = -d_2 = z = 0.5$$

←  $w_1$        $w_2$  →

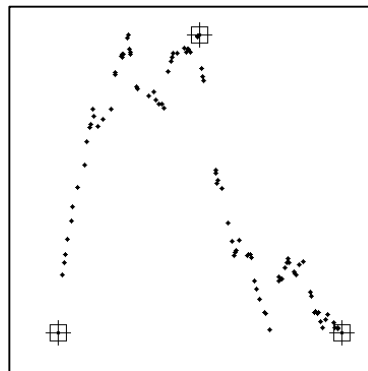
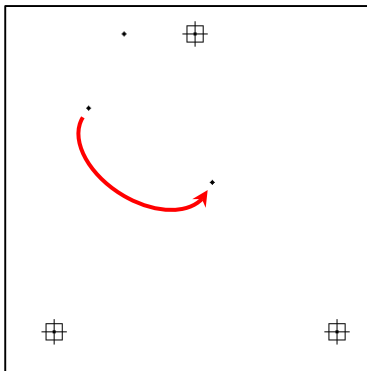
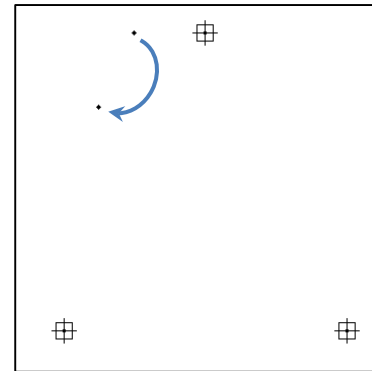
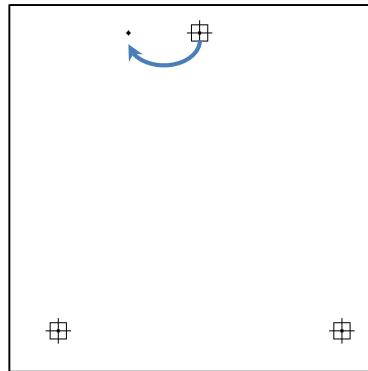
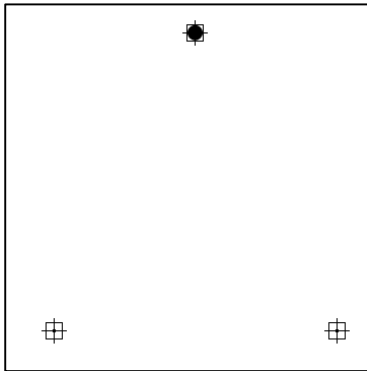

# Tossing a coin...

$$d_1 = -d_2 = z = 0.5$$

←  $w_1$        $w_2$  →

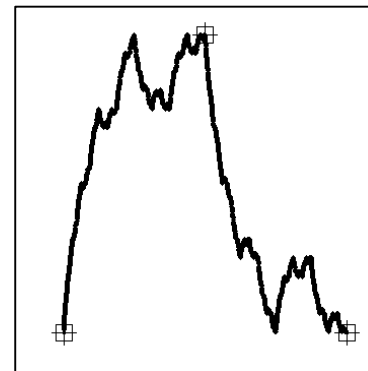
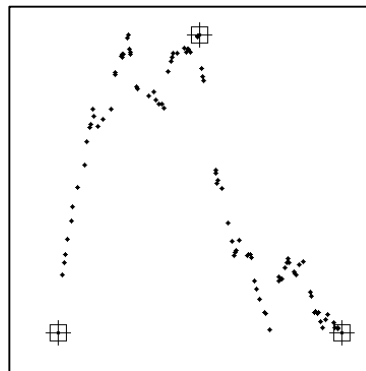
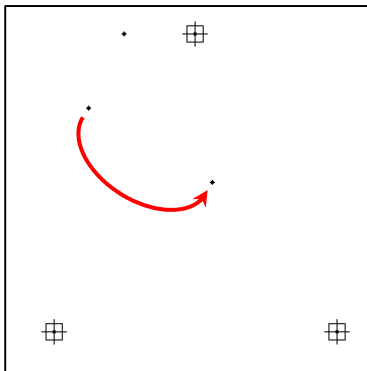
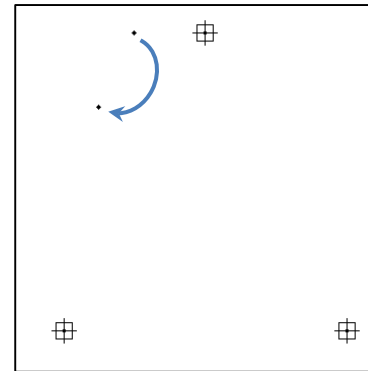
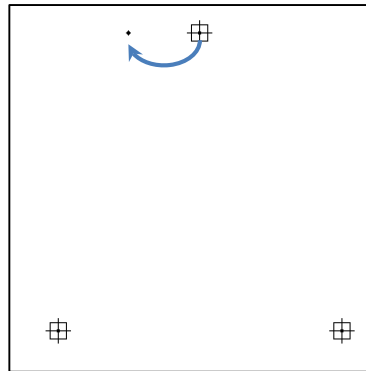
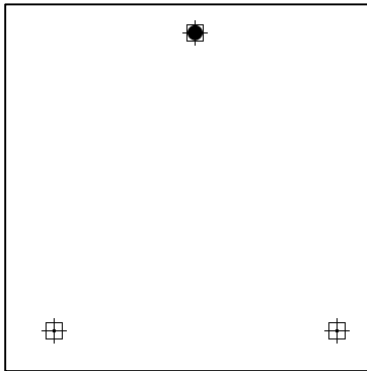

**fractal  
mountain**

# A matter of signs

*(Barnsley, 1988)*

$$w_1(x, y) = \left( \frac{x}{2}, x + d_1 \cdot y \right), w_2(x, y) = \left( \frac{x}{2} + \frac{1}{2}, 1 - x + d_2 \cdot y \right)$$

$$|d_1| = |d_2| = z$$

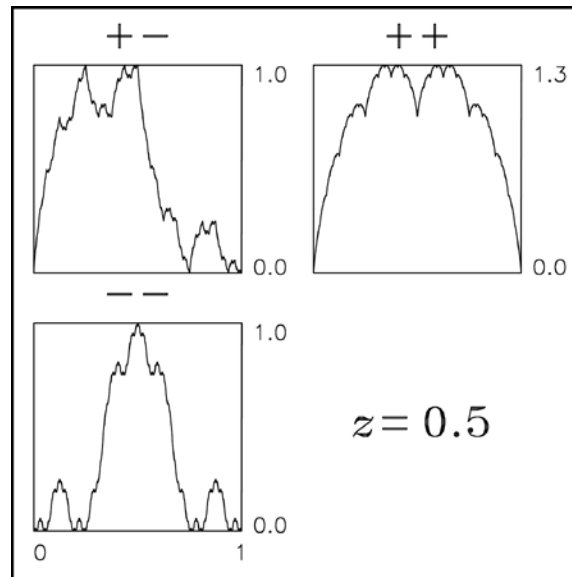

# A matter of signs

$$w_1(x, y) = \left( \frac{x}{2}, x + d_1 \cdot y \right), w_2(x, y) = \left( \frac{x}{2} + \frac{1}{2}, 1 - x + d_2 \cdot y \right)$$

$$|d_1| = |d_2| = z$$

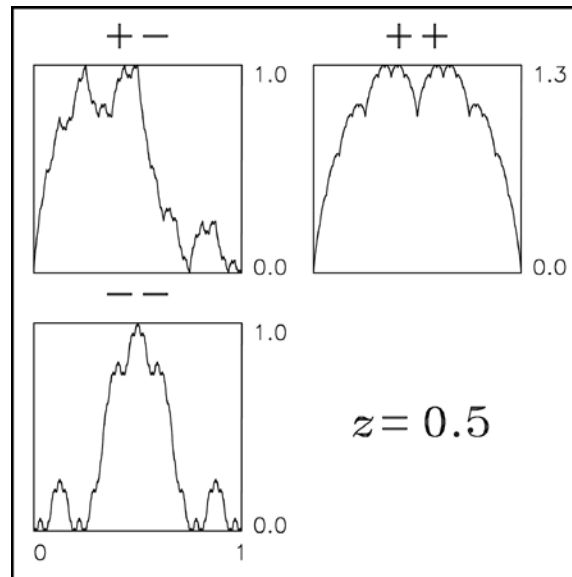

**case + -** is the *mountain*

**case - -** alternates **down** and **up**

**case + +** always goes **up** and yields a *cloud* (!)



# A matter of dimension

$$w_1(x, y) = \left( \frac{x}{2}, x + d_1 \cdot y \right), w_2(x, y) = \left( \frac{x}{2} + \frac{1}{2}, 1 - x + d_2 \cdot y \right)$$

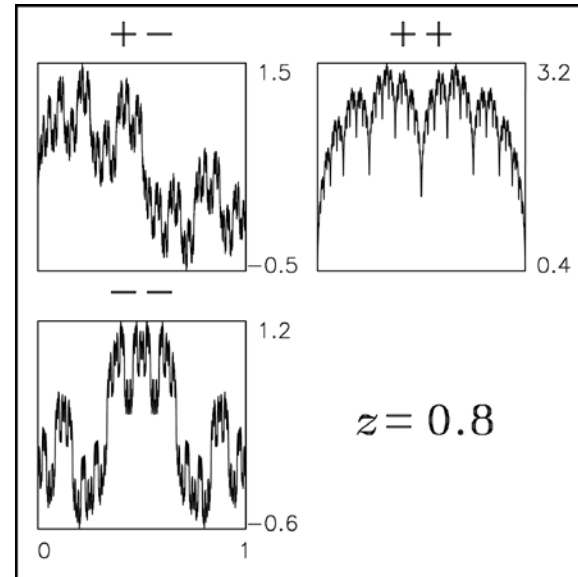
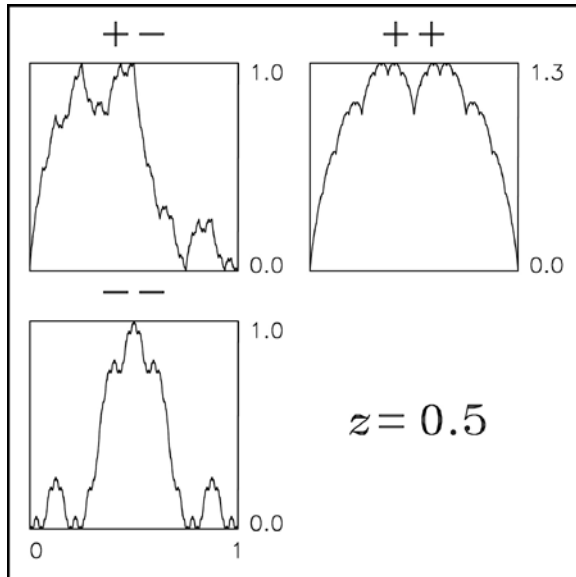

as  $z$  increases, the “wires” become **infinite** and fill more space

# A matter of dimension

$$w_1(x, y) = \left( \frac{x}{2}, x + d_1 \cdot y \right), w_2(x, y) = \left( \frac{x}{2} + \frac{1}{2}, 1 - x + d_2 \cdot y \right)$$

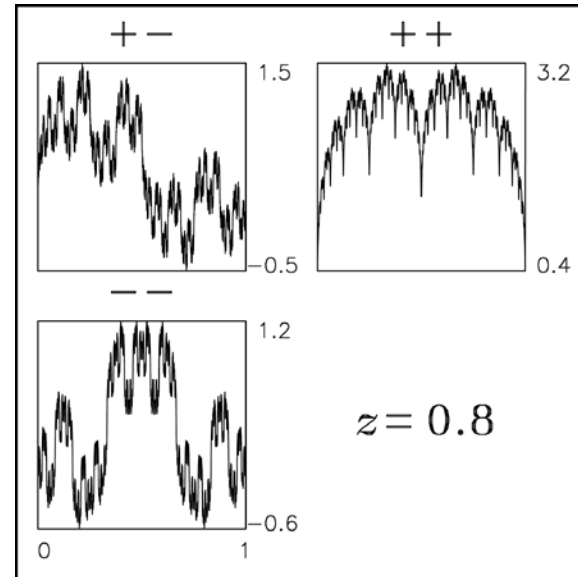
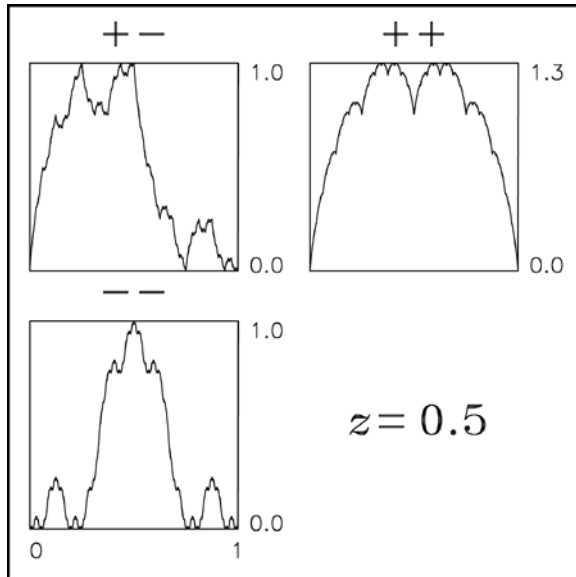

as  $z$  increases, the “wires” become **infinite** and fill more space  
as  $z$  tends to 1, their **fractal dimensions** tend to 2

# A matter of coins

50-50

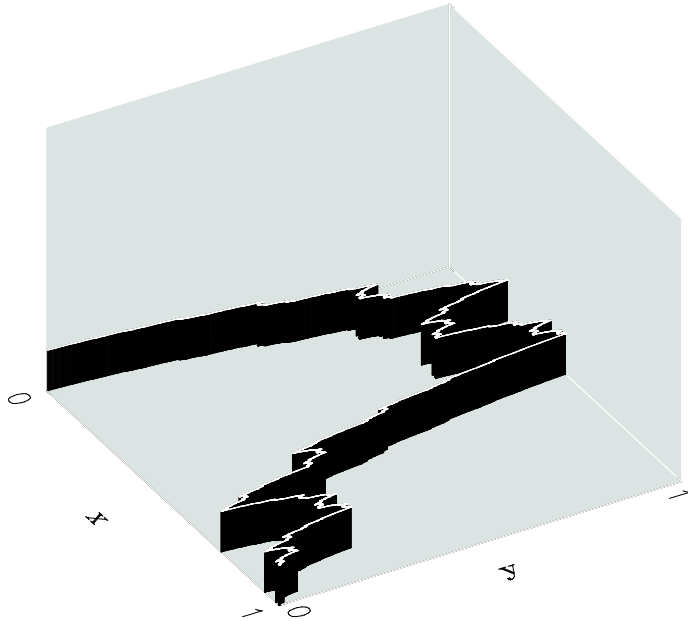

70-30

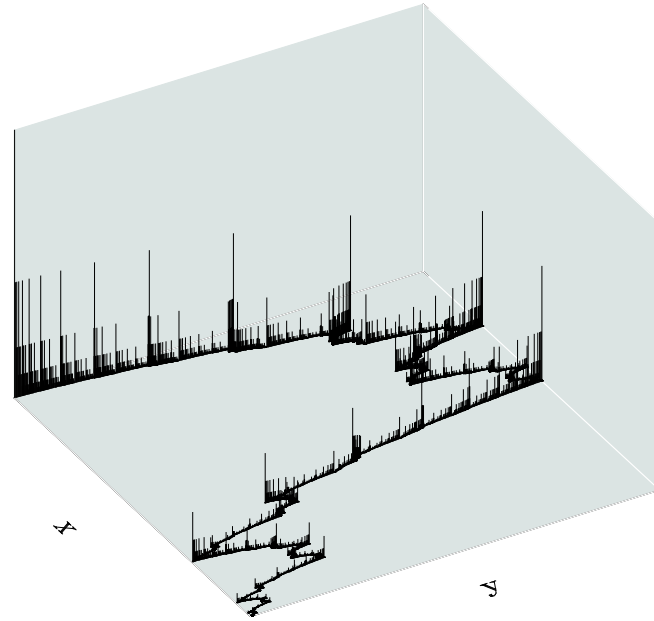

different **textures** over the same **wire** (*Elton's theorem*)

# A matter of coins

50-50

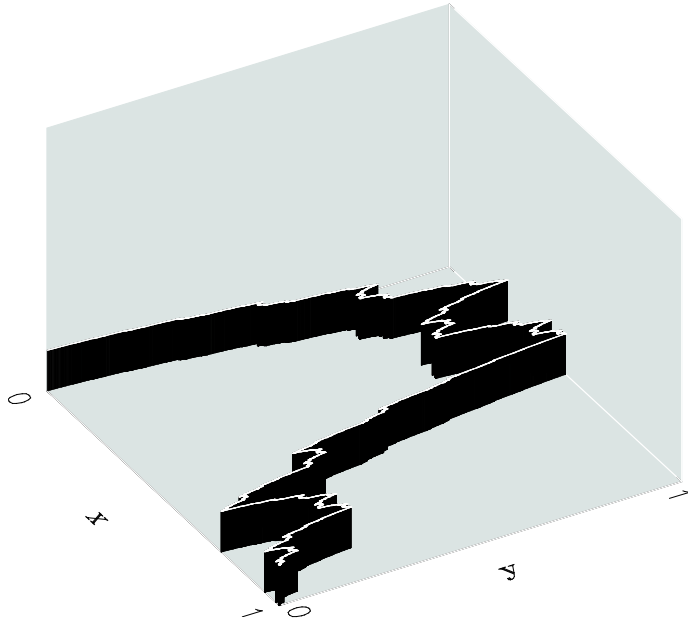

70-30

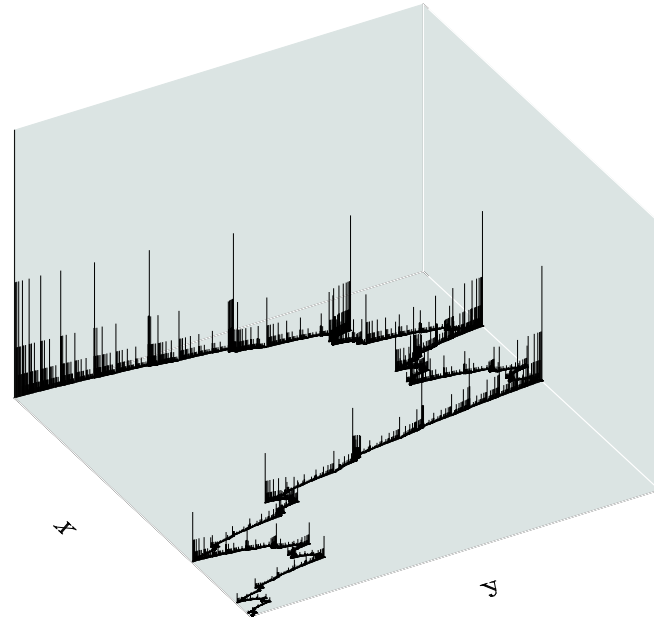

different **textures** over the same *wire* (*Elton's theorem*)

a relevant **idea**: what is seen from the two axes?

# A matter of coins

50-50

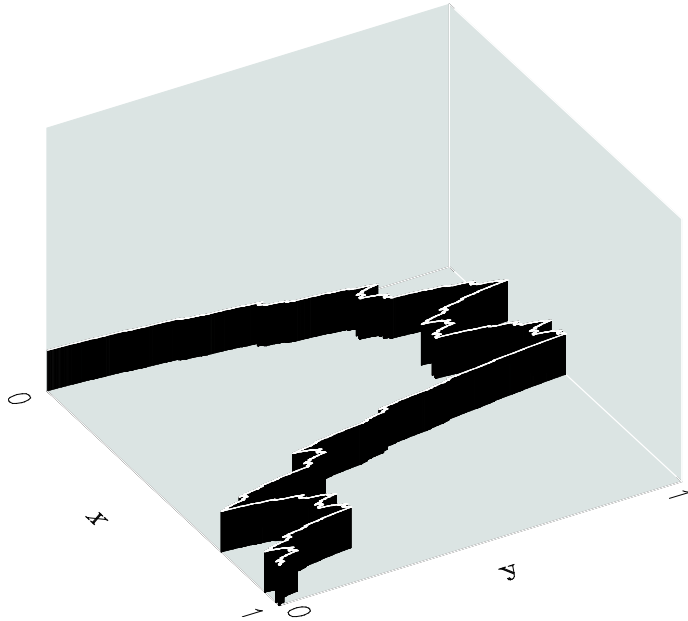

70-30

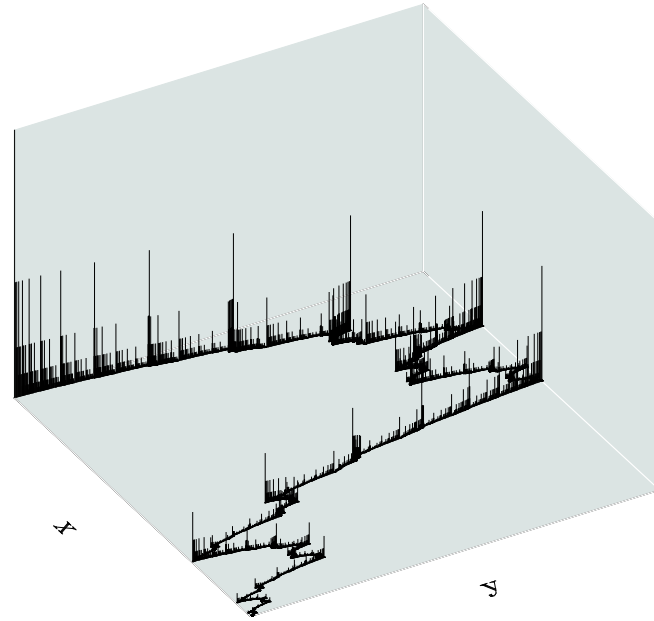

different **textures** over the same *wire* (*Elton's theorem*)

a relevant **idea**: what is seen from the two axes?

I knew what happened over  $x$ , but perhaps **Hydrology** from  $y$ ?

# The projection over $x$

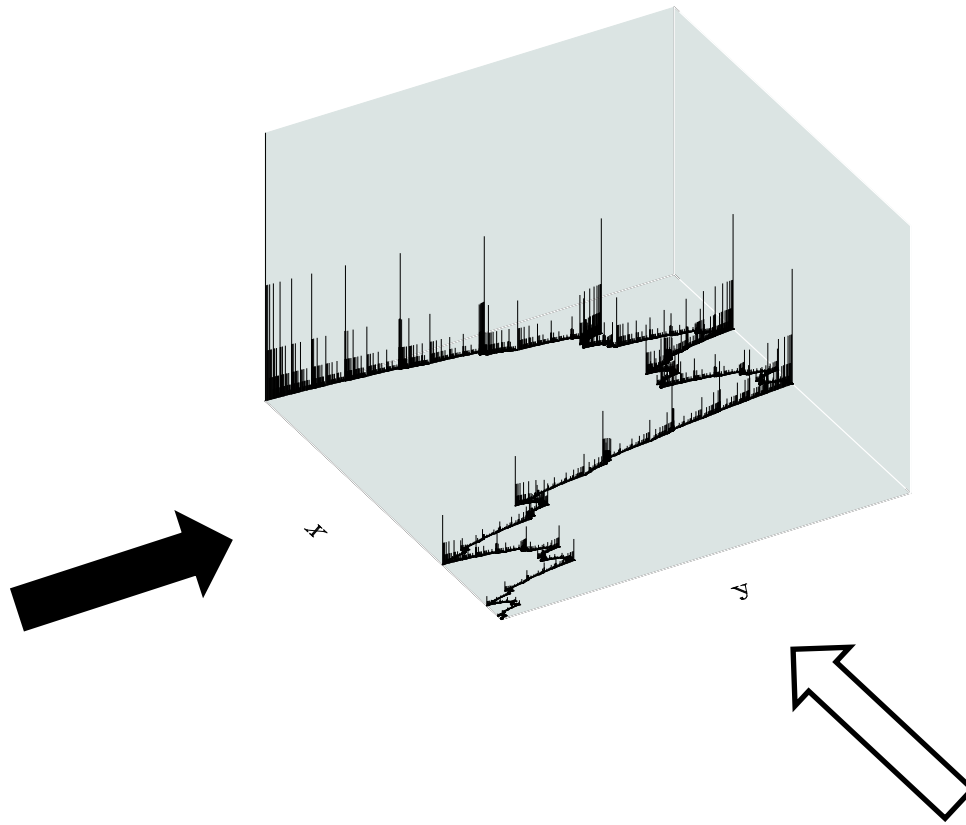

# Turbulence and multifractals

*(Meneveau and Sreenivasan, 1987)*

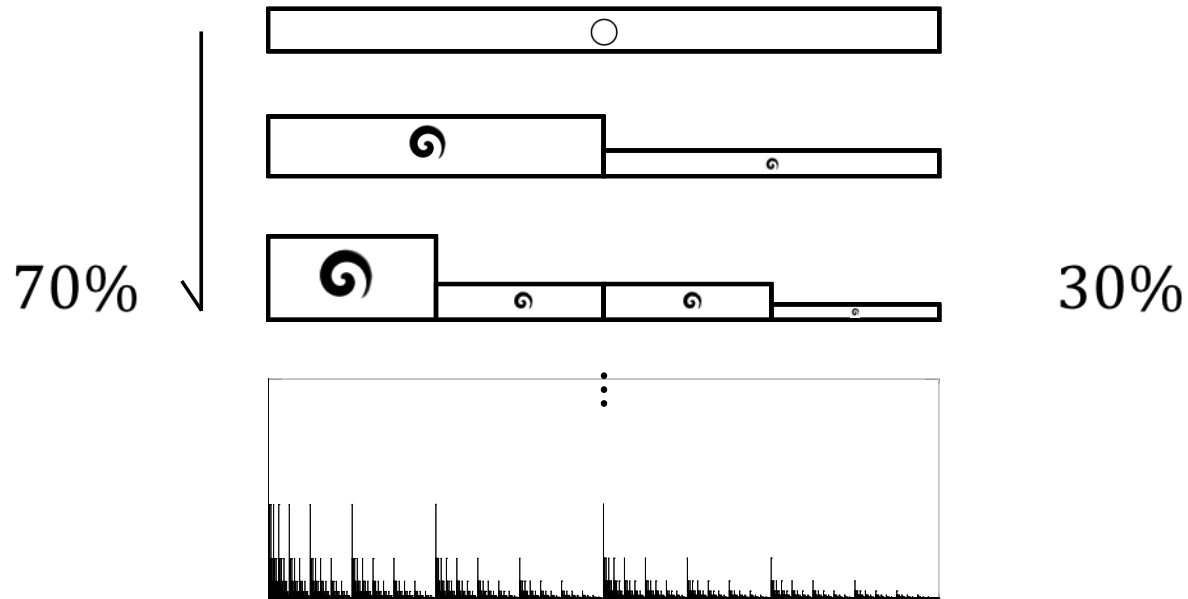

a cascade of **eddies** generating intermittent **violence**

# Turbulence and multifractals

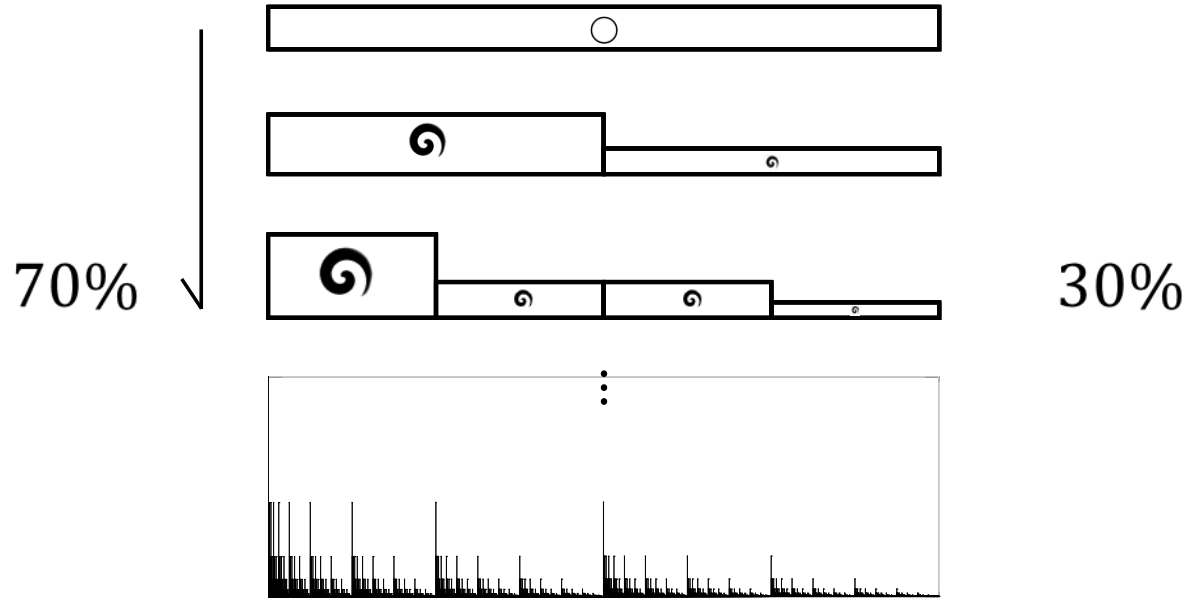

a cascade of **eddies** generating intermittent **violence**  
multiple **fragmentation** yielding **thorns** and **dust**



# Turbulence and multifractals

*(Puente, 2006)*

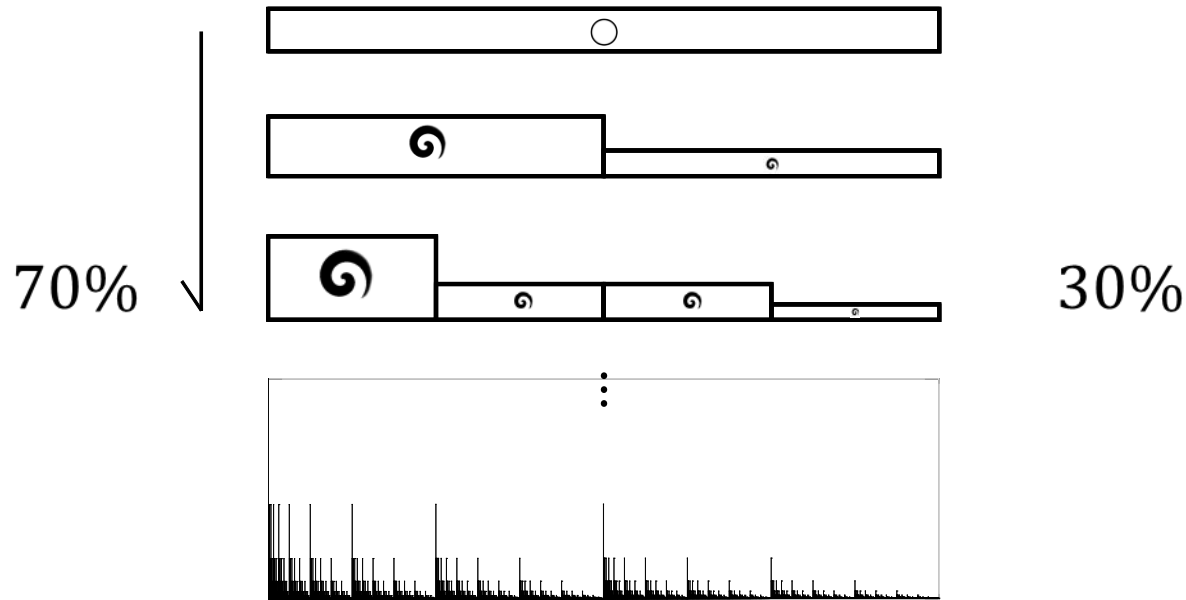

a cascade of **eddies** generating intermittent **violence**  
multiple **fragmentation** yielding **thorns** and **dust**  
a **dissipative** process, also in economic **inequalities**...

# The projection over $y$

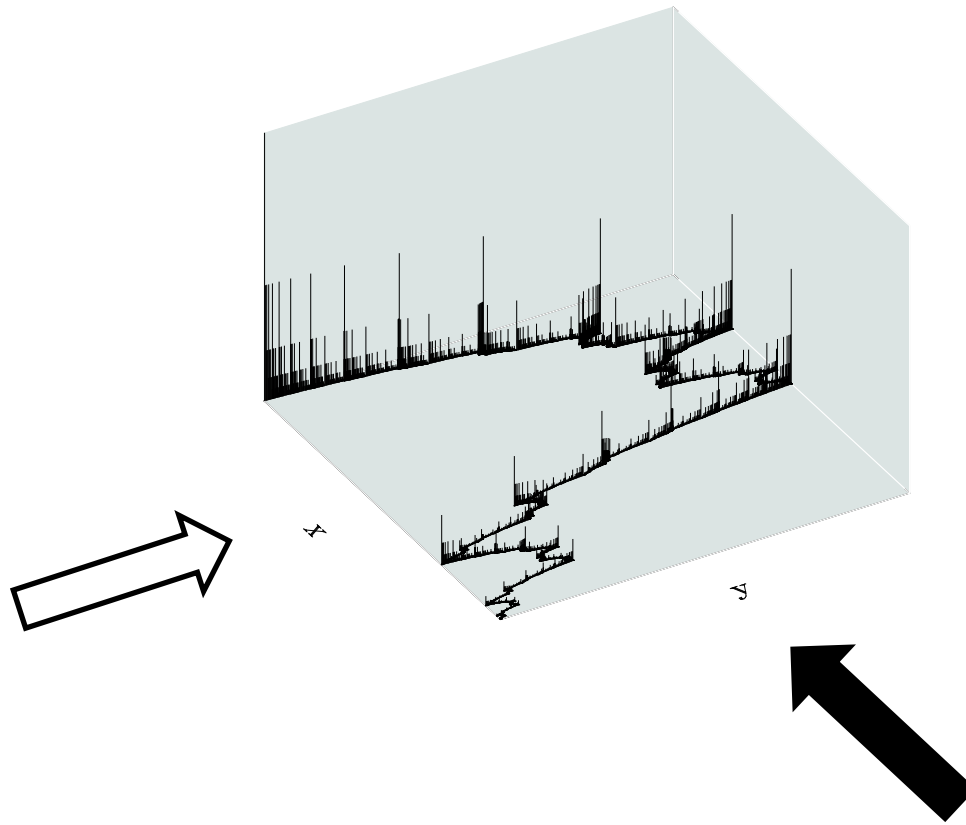

# Plato was right!

*(Puente, 1992, 1996)*

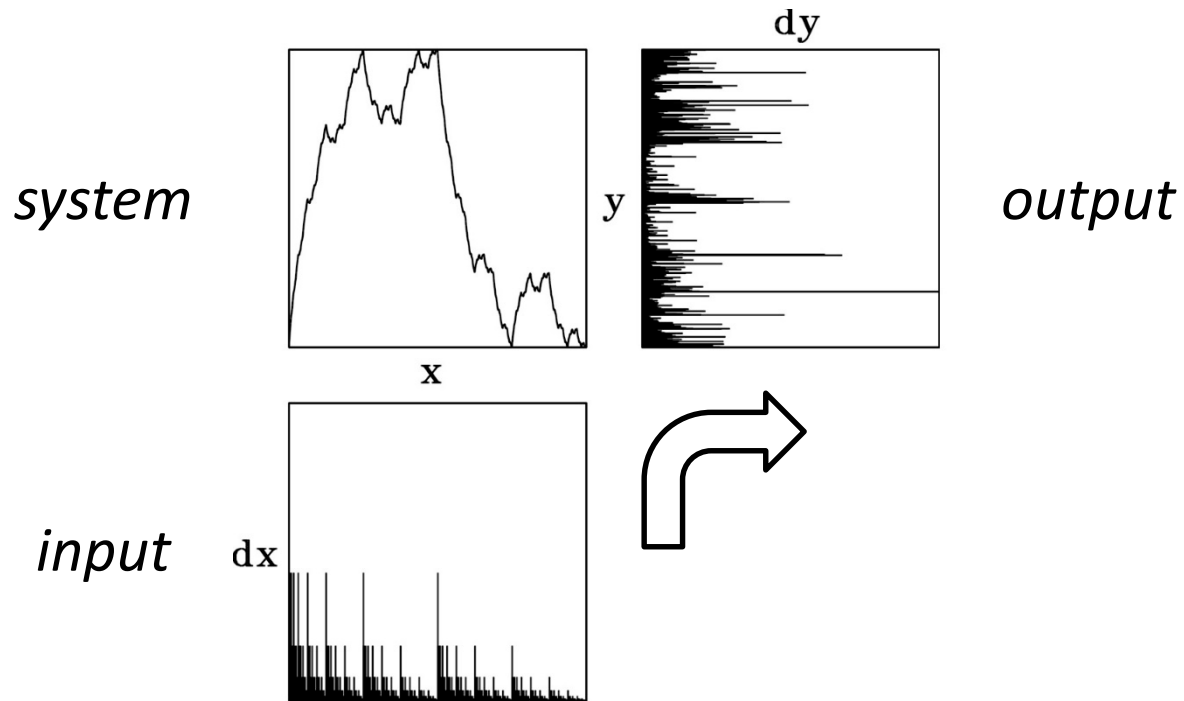

# Plato was right!

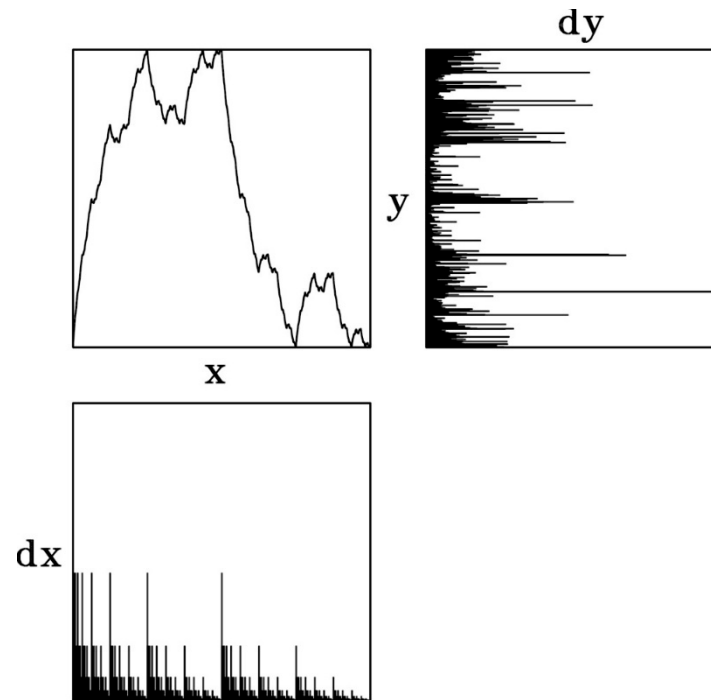

$dx$  “*illuminates*” the wire and  $dy$  is its “*shadow*”

# Plato was right!

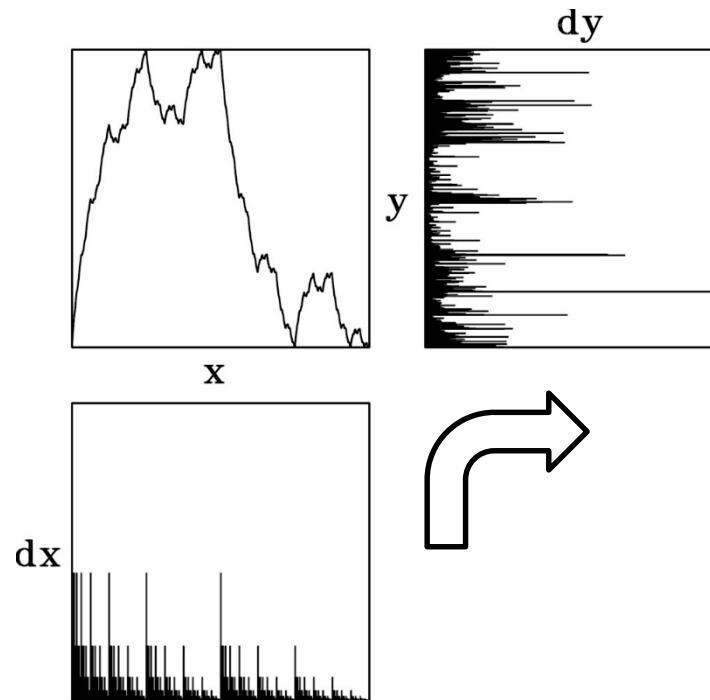

$dx$  “illuminates” the wire and  $dy$  is its “shadow”

$dy$  is a **transformation** of **turbulence**

# Plato was right!

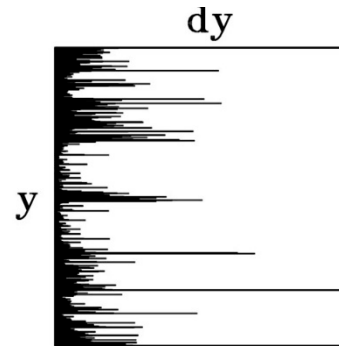

$dx$  “*illuminates*” the wire and  $dy$  is its “*shadow*”

$dy$  is a **transformation** of turbulence

the projection  $dy$  appears **random**, but it is not (!)

# Shadows and no more!

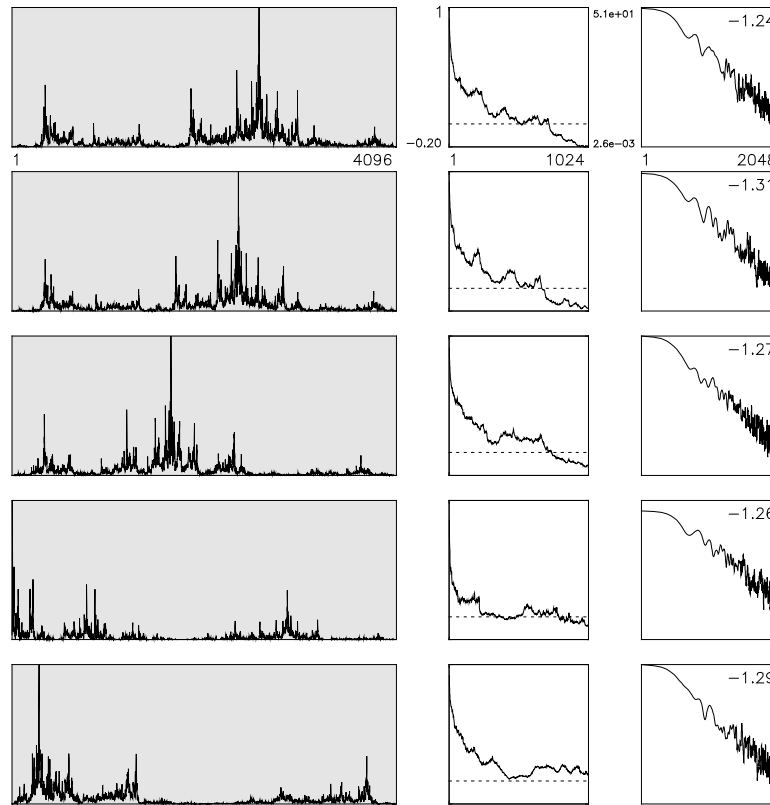

varying the parameters of the construction (and generalizations)  
produces shapes and statistics similar to **natural** data (!)

# A useful idea in hydrology

*(Puente and Obregón, 1996)*

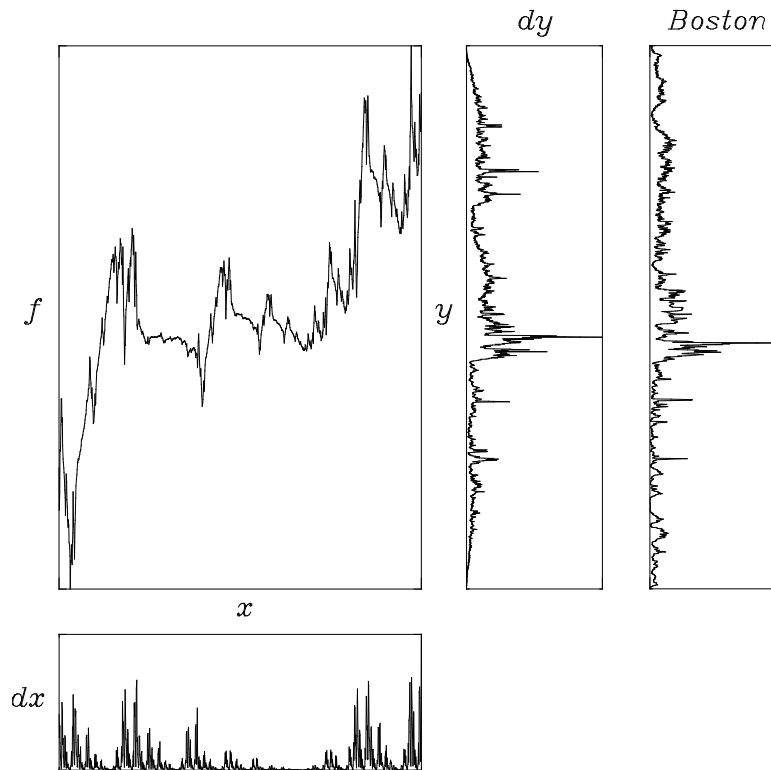

a model (left) of **rainfall** data in Boston (right)



# A useful idea in hydrology

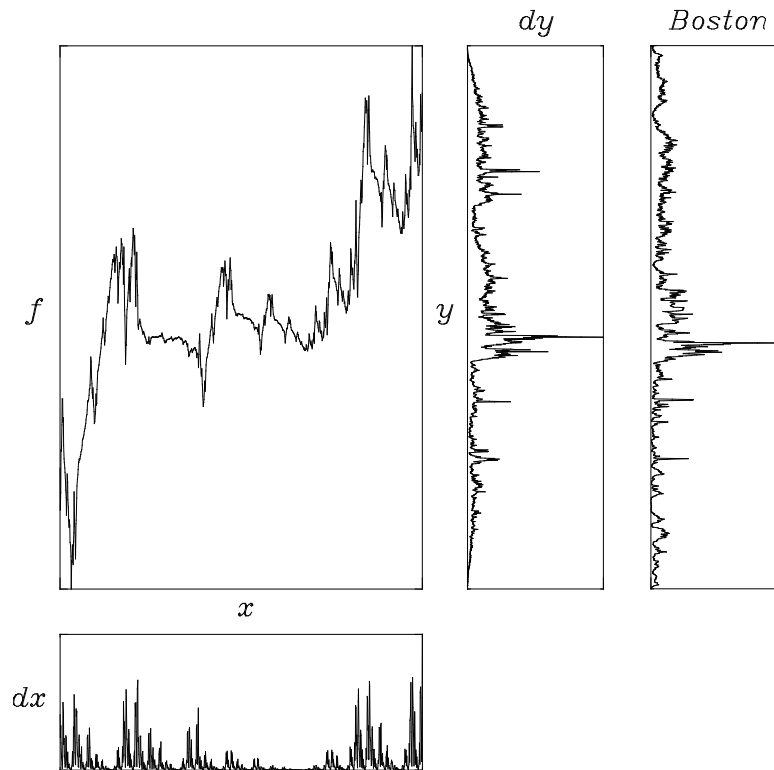

a model (left) of *rainfall* data in Boston (right)

useful for *stream flows* and *economic* data, but the **limit** is better...

# Case + -, $z \rightarrow 1$

*(Puente et al., 1996)*

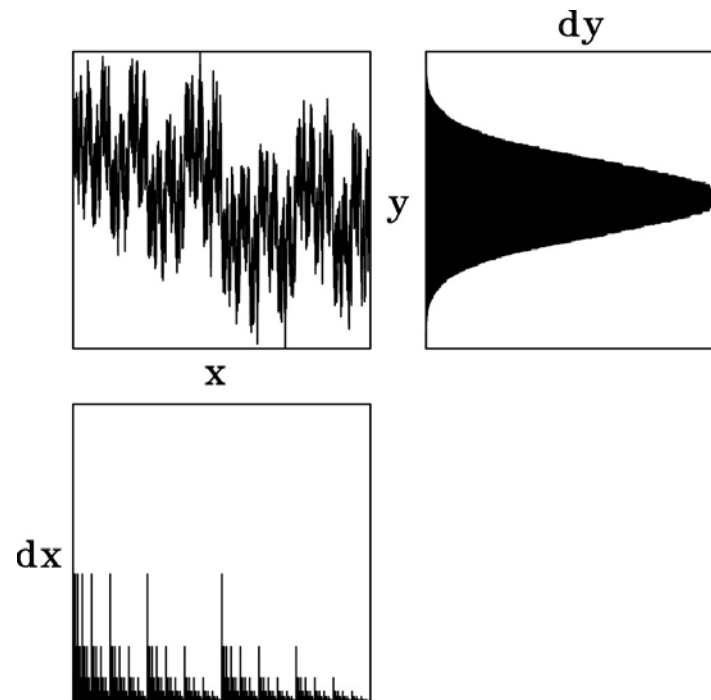

# Case + -, $z \rightarrow 1$

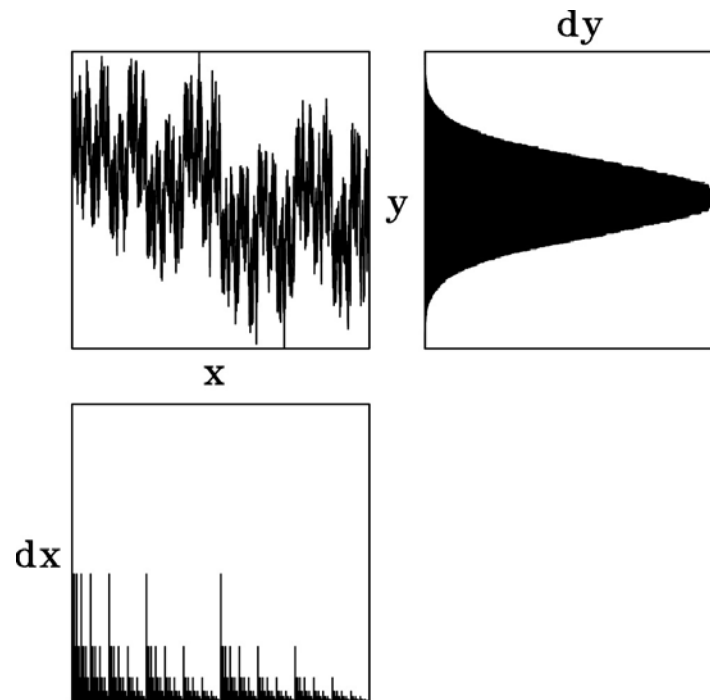

$dy$  is a *Gaussian bell curve* for any non-discrete  $dx$  (!)

# Case + -, $z \rightarrow 1$

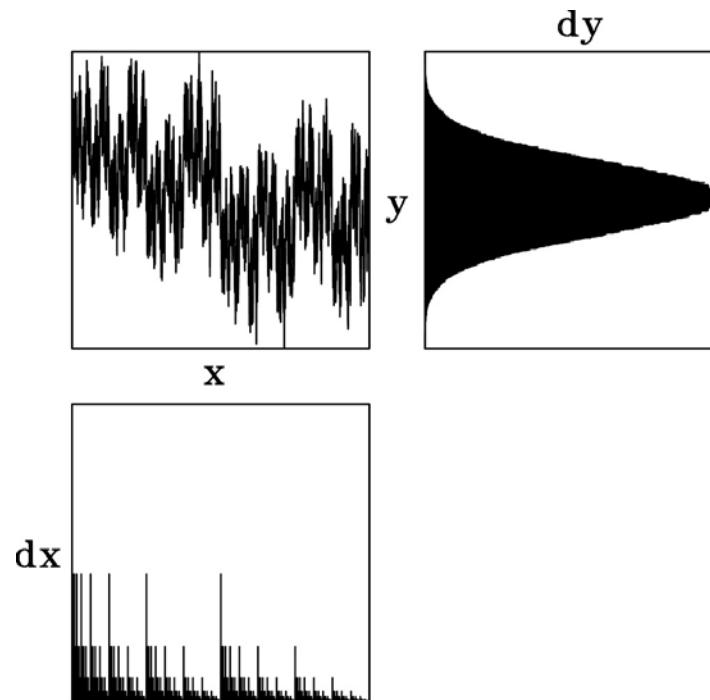

$dy$  is a *Gaussian bell curve* for any non-discrete  $dx$  (!)

a surprising **BRIDGE** from **dissipation** to **conduction** (!)

# Case + -, $z \rightarrow 1$

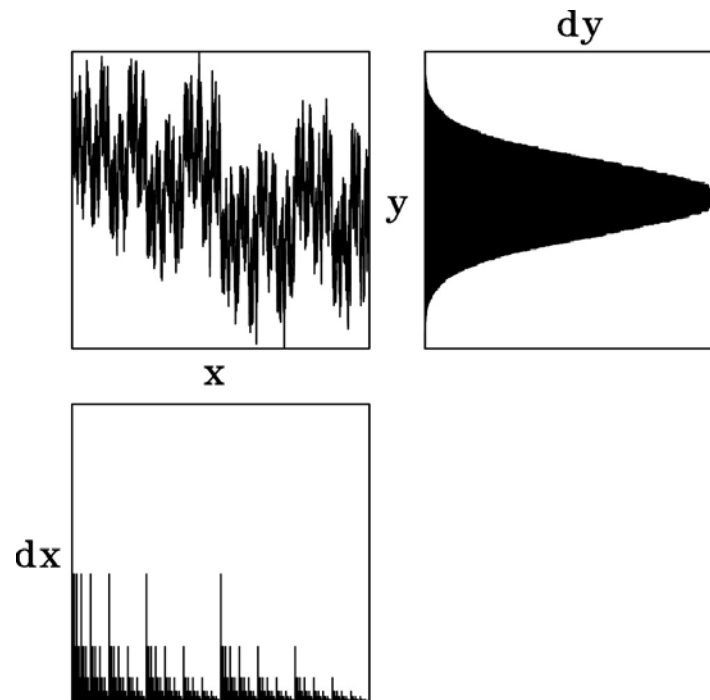

$dy$  is a *Gaussian bell curve* for any non-discrete  $dx$  (!)

a surprising *BRIDGE* from **dissipation** to **conduction** (!)

**case - -** produces **oscillations** between two bells

# Case + +, $z \rightarrow 1$

*(Puenta, 2011b)*

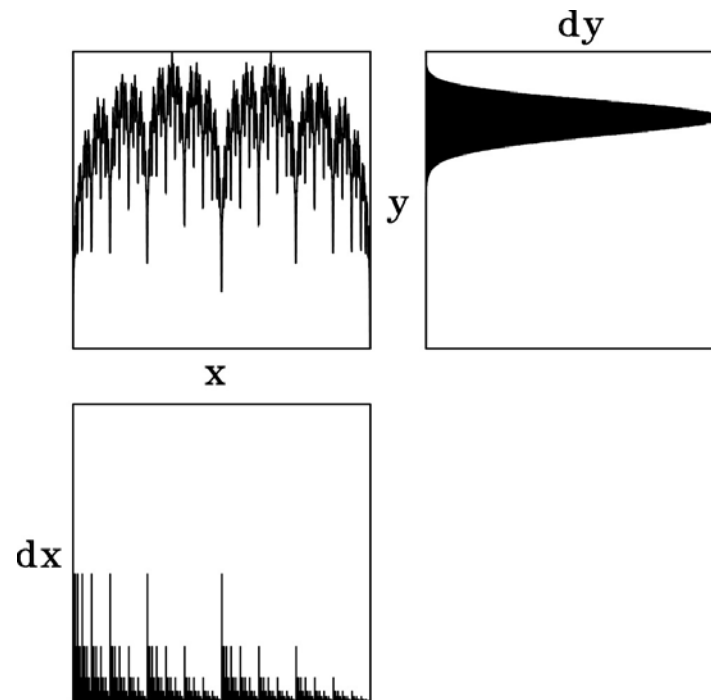

# Case + +, $z \rightarrow 1$

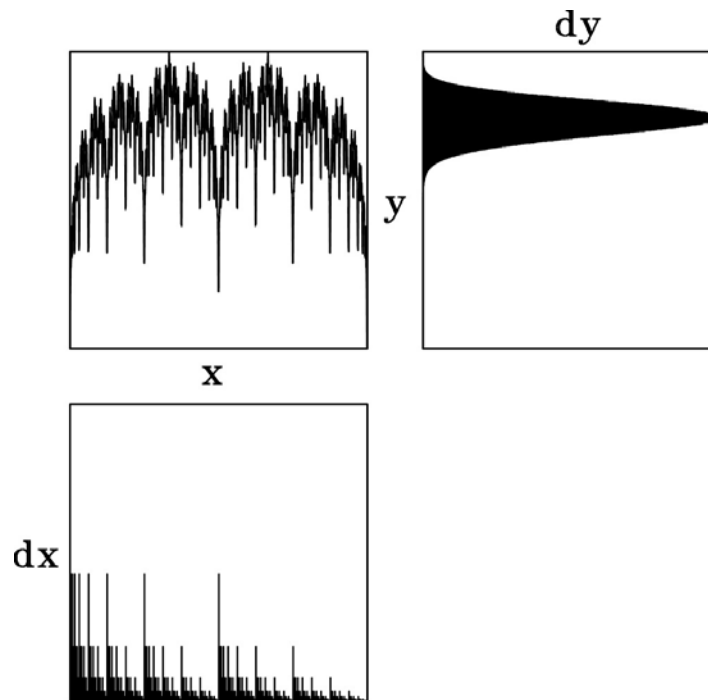

a *luminous* and *singular* bell *concentrated* at *infinity* (!)

# Case + +, $z \rightarrow 1$

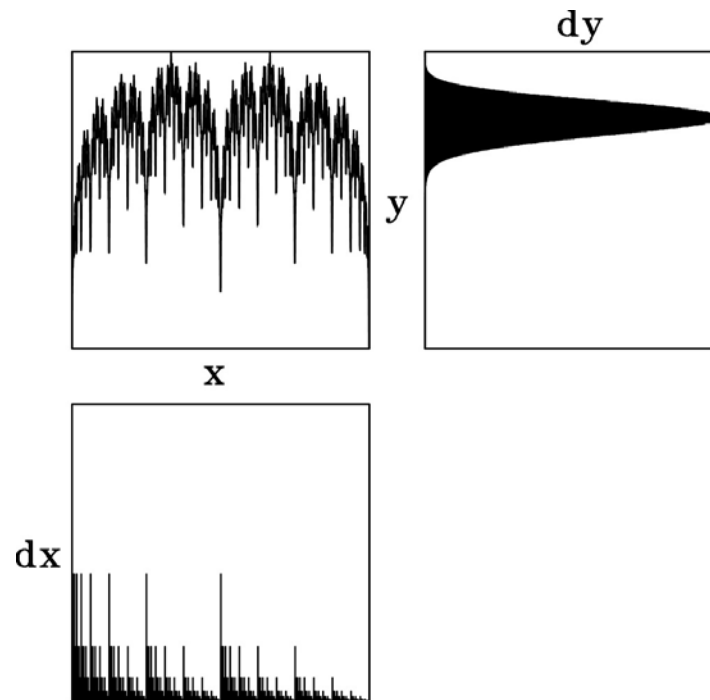

a *luminous* and *singular* bell *concentrated* at infinity (!)

the most **positive wire** filters *almost any disorder* (!)



# Case + +, $z \rightarrow 1$

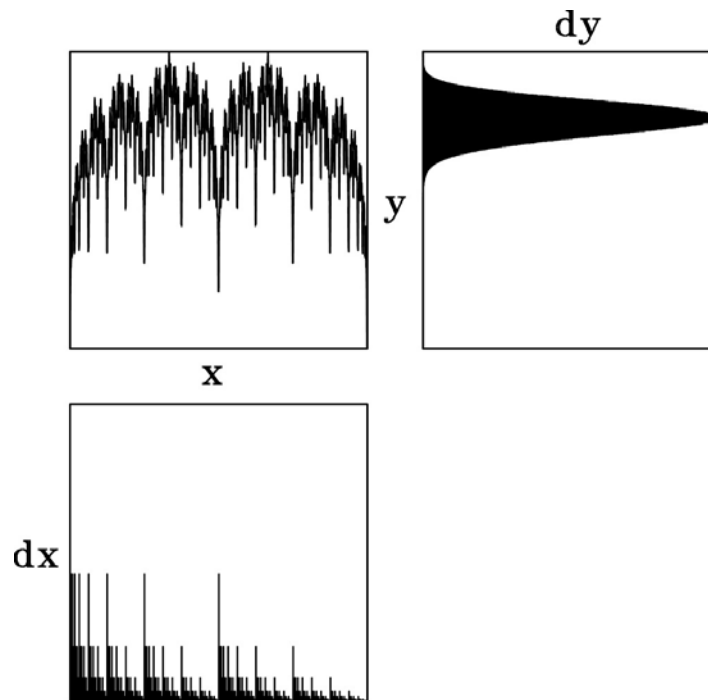

a *luminous* and *singular* bell *concentrated* at infinity (!)

the most **positive** wire filters *almost any* disorder (!)

**What is the transformation? Is it LOVE? I shared with friends...**

# True wisdom at MIT



*Álvaro* and *Elizabeth*, my spiritual godfathers, with *David*

# True wisdom at MIT

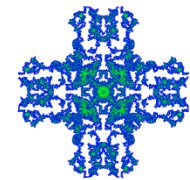

*Álvaro* and *Elizabeth*, my spiritual godfathers, with *David*  
it all points to **God**, have you had an experience with **Him**?  
it is **key** to enter the **Kingdom of God**, **John 3**

# Attempting the algorithm at 32



my mom had died **tragically** when I was 20 years old

# Attempting the algorithm at 32



my mom had died **tragically** when I was 20 years old  
my heart was filled with **pain** and I had “nothing to lose”

# Attempting the algorithm at 32



my mom had died **tragically** when I was 20 years old  
my heart was filled with **pain** and I had “nothing to lose”  
*forgiving and asking for forgiveness* I had a **mystical** experience

# Attempting the algorithm at 32



my mom had died **tragically** when I was 20 years old  
my heart was filled with **pain** and I had “nothing to lose”  
*forgiving and asking for forgiveness* I had a **mystical** experience  
the + + diagram became personal: **I was born again!**

# Attempting the algorithm at 32

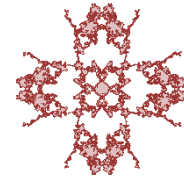

my mom had died **tragically** when I was 20 years old  
my heart was filled with **pain** and I had “nothing to lose”  
*forgiving and asking for forgiveness* I had a **mystical** experience  
the + + diagram became personal: **I was born again!**  
what a marvelous event! was it?



# A bit more suffering...

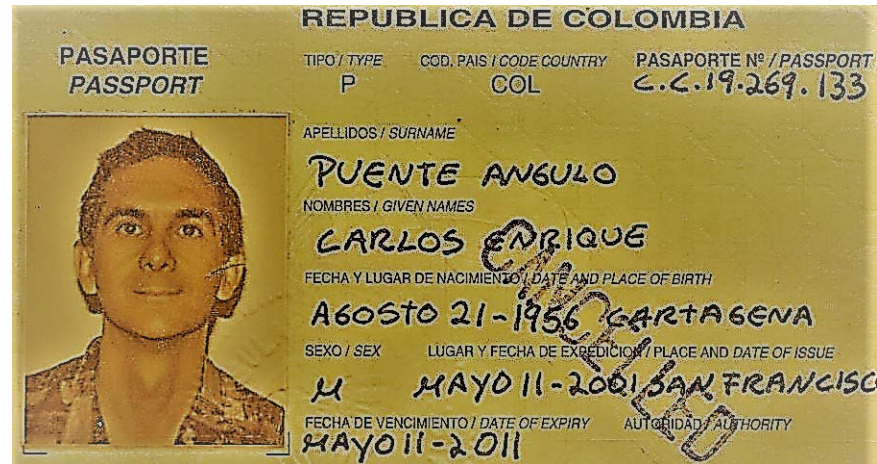

I couldn't sleep and ended up in a hospital for a month

# A bit more suffering...

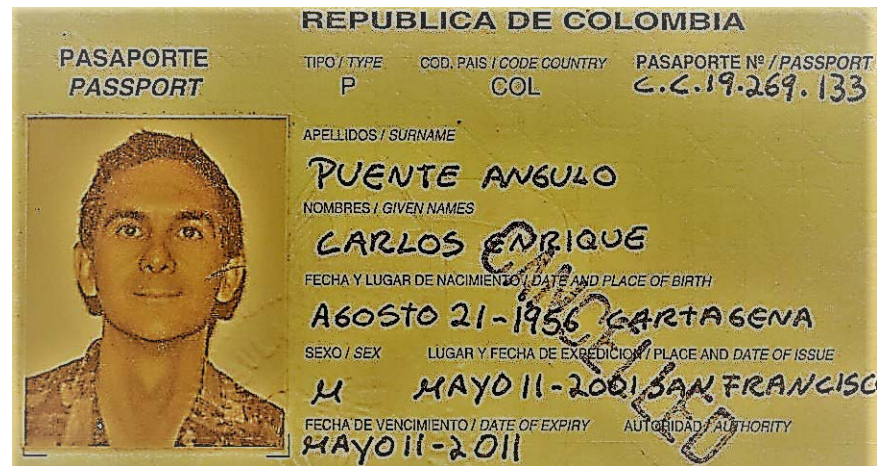

I couldn't sleep and ended up in a hospital for a month after 8 years of marriage, my wife left and it all ended in an annulment

# A bit more suffering...

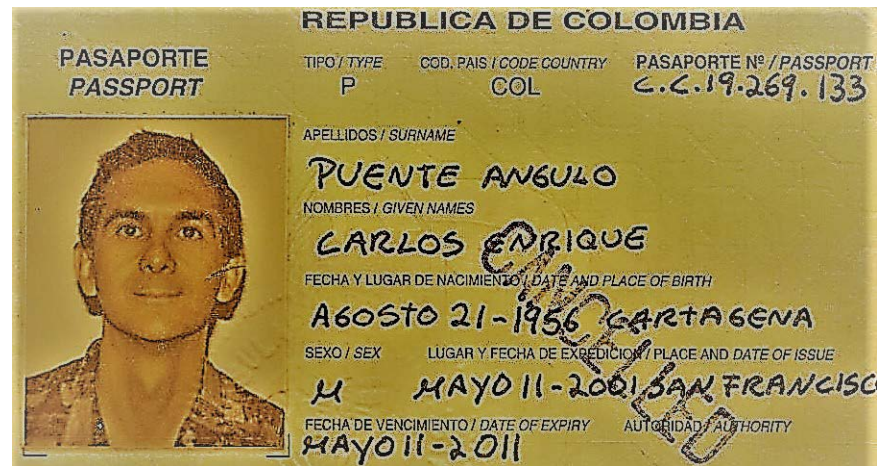

I couldn't sleep and ended up in a hospital for a month after 8 years of marriage, my wife left and it all ended in an annulment the university gave me a leave of absence and I went to Colombia

# A bit more suffering...

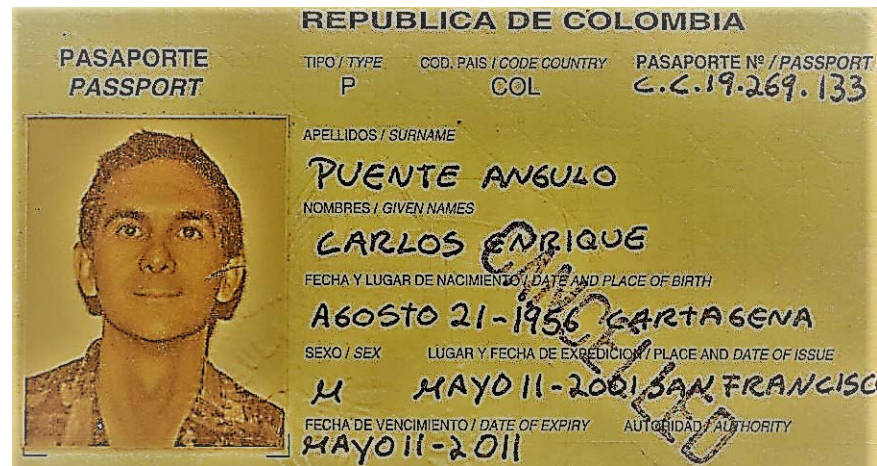

I couldn't sleep and ended up in a hospital for a month after 8 years of marriage, my wife left and it all ended in an annulment the university gave me a leave of absence and I went to Colombia there I met my "second" wife and the annulment repeated

# A bit more suffering...

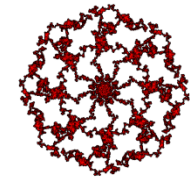
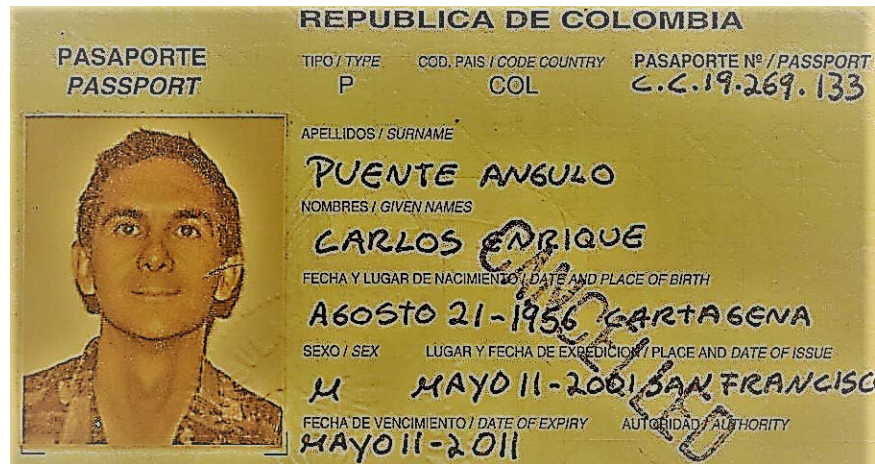

I couldn't sleep and ended up in a hospital for a month after 8 years of marriage, my wife left and it all ended in an annulment the university gave me a leave of absence and I went to Colombia there I met my "second" wife and the annulment repeated ...but I read the **Bible** truly conscious that **God** was present (!)

# In due time, growing the faith...



as promised, *reconciliation* with **God** for *all the family*:  
my dad *Carlos*, stepmother *Connie* and sisters *Patricia* and *Xiomara*

# In due time, growing the faith...

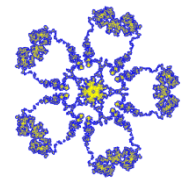

as promised, *reconciliation* with **God** for *all the family*:  
my dad *Carlos*, stepmother *Connie* and sisters *Patricia* and *Xiomara*  
hydrologist *John the Baptist* became my hero... (!)

# **To be born again**

*(Puente, 2018)*



To be born again  
is very lovely,  
is to find the sun  
within yourself.

To be born again  
is so glorious,  
that all appears  
so very blessed.

To be born again  
is truly amazing,  
is to find inside  
whole immensity.

To be born again  
is so grandiose,  
that dreams become  
real mighty bell.

**We forgive  
and better love everyone,  
and at once  
we truly make an effort,  
and heads on  
towards the light we go,  
and the eternal triune  
lights up in our heart.**

To be born again  
is very lovely,  
is finding water  
to satiate your thirst.

To be born again  
is so glorious,  
that removes gripes  
sending us to pray.

To be born again  
is truly amazing,  
is to hear the voice  
bribe for your faith.

To be born again  
is so grandiose,  
for now you know  
God loves very well.

**We forgive  
and better love everyone,  
and at once  
we truly make an effort,  
and heads on  
towards the light we go,  
and the eternal triune  
lights up in our heart...**

*(July 2000/July 2023)*

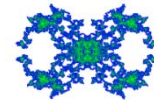

# My blessings from on high



*Marta, my first wife, Cristina and Mariana (!)*

# My blessings from on high



*Marta*, my first wife, *Cristina* and *Mariana* (!)  
like **Job**, but not equally, a restored family

# My blessings from on high

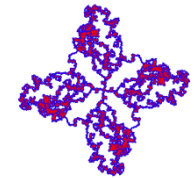

*Marta*, my first wife, *Cristina* and *Mariana* (!)  
like **Job**, but not equally, a restored family  
the **triune God** is the source of **true riches** (!)

# My pearls in science

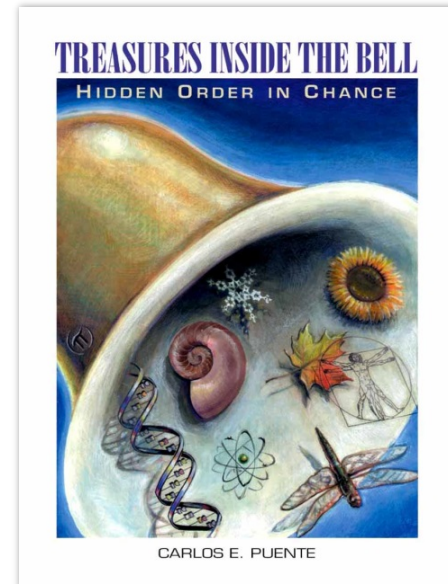
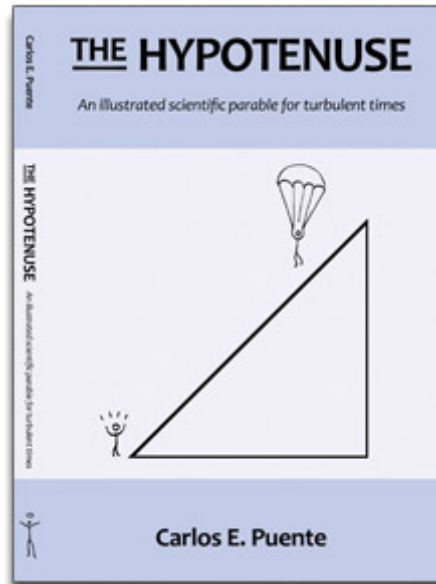
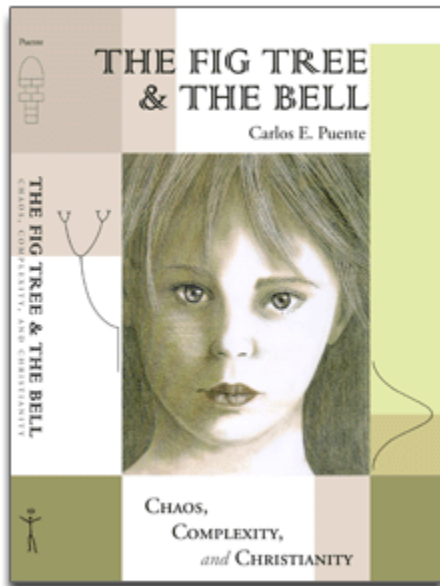

the first two also in Spanish, the second in Italian and Farsi



# My pearls in science

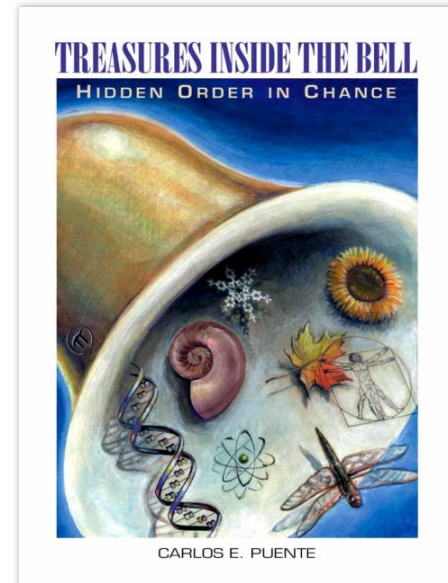
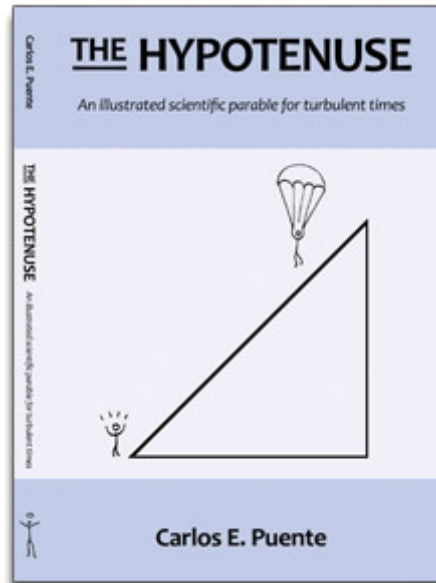
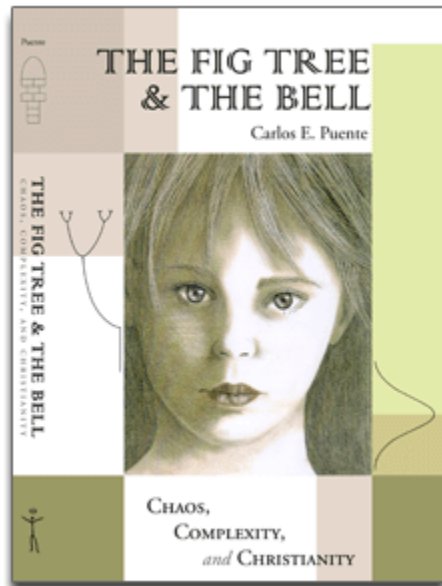

the first two also in Spanish, the second in Italian and Farsi  
seminar class **Chaos, Complexity & Christianity** from 2001 to 2021

# My pearls in science

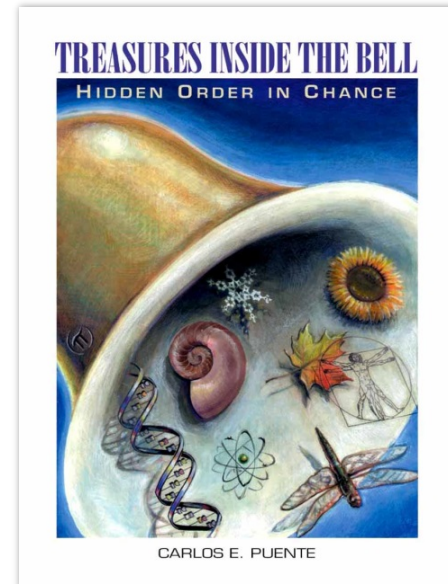
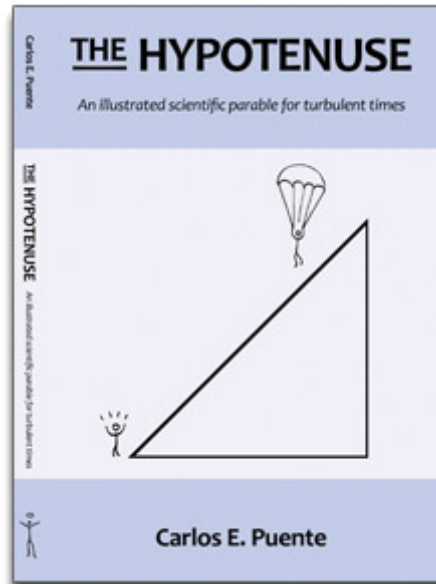
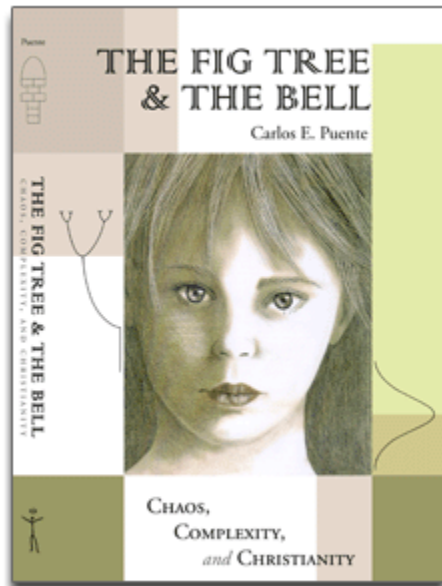

the first two also in Spanish, the second in Italian and Farsi  
seminar class **Chaos, Complexity & Christianity** from 2001 to 2021

blog <https://campanitasdefe.com>

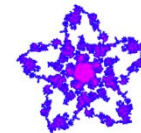

# **Other Lessons**

*(Puente, 2017, 2020b)*

# Other Lessons

1. Presentation: the faith of a hydrologist
2. An introduction to fractals and complexity
3. Jesus, the way, truth, life, and hypotenuse  $Y = X$
4. Turbulence and the Bible
5. The deterministic nature of chaos
6.  $Y = X$ : the narrow gate and the only way to the Father
7. Urgent biblical symbols in fig trees of science
8. A geometric model of the Most Holy Trinity
9. The central plea from the bell at infinity
10. The exponential surprise and the laws of no power
11. The ever vibrant splendor of peace
12. A new song: Shanti Setú or Puente de Paz

# Other Lessons

## ***2. An introduction to fractals and complexity***

*Revises the different kinds of numbers that exist, introduces examples of fractal sets, including Cantor dust and the Koch curve, contrasts order and chaos using the logistic map, and emphasizes the existence of “power-laws” related to natural violence.*

# Other Lessons

## ***3. Jesus, the way, truth, life, and hypotenuse $Y = X$***

*Explains, based on generic models of division and turbulence, that Jesus Christ is certainly the way, the truth and the life; and also the straight hypotenuse with equation  $Y = X$  that takes us to the Origin, God the Father (Jn 14:6). Argues that living in a loving and saintly manner, striving for uniformity and away from the dust of division, is our best option.*

# Other Lessons

## ***4. Turbulence and the Bible***

*Illustrates that Sacred Scripture contrasts calmness with turbulence in order to define our options. Explains how, using such a symbolism, God invites us to conversion, rectitude, and the unity of love. Reminds us of actions we may take in order to experience balance in our lives.*

# Other Lessons

## ***5. The deterministic nature of chaos***

*Studies the iterating dynamics of the “logistic map” to explain how it gives rise to a celebrated scientific diagram, the Feigenbaum tree (the fig tree in German), which contains repetitive or periodic behaviors and also others that, by being dusty and lacking repetition, properly define what is chaos. Introduces the Hénon and Lorenz attractors to explain that the famous “butterfly effect” is a common feature of chaos.*



# Other Lessons

## ***6. $Y = X$ : the narrow gate and the only way to the Father***

*Shows how the Feigenbaum tree provides suitable images that allow us to visualize the final destinies of mankind, including an improbable and truthful purged escape from the most ardent and infernal chaos. Argues that coming down the fig tree, by its implied conversion and abandonment to goodness under the straight line  $Y = X$ , is essential for us to enter the “Kingdom of God”.*

# Other Lessons

## ***7. Urgent biblical symbols in fig trees of science***

*Explains how the Feigenbaum tree yields auspicious symbols that allow representing diverse biblical passages, including those related to fig trees, like the fall of Adam and Eve ending covered with fig leaves; the cursing of a fig tree by Jesus when he was returning to Jerusalem before giving his life for us; and the parable of the fig tree associated with his return. Invites us to be prepared for the second coming of Jesus and exhibits the full protection of the “elect” who make up the “Body of Christ” and “The Church”.*

# Other Lessons

## ***8. A geometric model of the Most Holy Trinity***

*Employing a fractal function shaped as angel wings and containing infinite unity, exposes a geometric model of the Holy Spirit, and, based on it and via projections, introduces a united representation of the tree members of the Most Holy Trinity, in which the Son is represented by uniformity and the Father by a bell curve concentrated at infinity. Shows how such a construction is useful to talk about Jesus Christ as our Savior and to consider other matters of faith.*

# Other Lessons

## ***9. The central plea from the bell at infinity***

*Illustrating important biblical events as transitions from disorder to order, reminds us of sublime love in the Most Holy Trinity, which ought to be accepted in plenitude. Shows that only in the abandonment to the positive cross, satisfying a vital limit theorem day by day, there is the peace and joy that takes us to God the Father in the bell curve concentrated at infinity.*

# Other Lessons

## ***10. The exponential surprise and the laws of no power***

*Explains how the famous passage of the Vine and the branches (Jn 15:1-10) gives rise to unforeseen exponential representations of the Holy Spirit and the Eucharistic Doxology. Exhibits “power-laws” in natural violence and in the one induced by mankind and calls us to avoid such laws and strive for sanctity instead.*

# Other Lessons

## ***11. The ever vibrant splendor of peace***

*Summarizes the message of the class in the imperious need for conversion and love and emphasizes the need to rely on the power of the Holy Spirit. Remembering some signals in these lessons, and others based on the alpha and the Omega seen in the sky and additional symbols in the Shroud of Turin, exhorts us to be attentive and prepared for the return of Jesus Christ.*

# Other Lessons

## ***12. A new song: Shanti Setú or Puente de Paz***

*Reiterates the arguments in these lessons employing a collection of songs aimed at singing to the Lord a new song.*

*...Well, now you know what the class is about.*

*Next time we shall talk about fractals and other elements that define complexity.*

*Until next time...*



# References

Barnsley, M. F. (1988) *Fractals Everywhere*, Academic Press.

Meneveau, C and K. R. Sreenivasan (1987) "Simple multifractal cascade model for fully developed turbulence", *Physical Review Letters* 59:1424.

Puente, C. E. (1992) "Multinomial multifractals, fractal interpolators, and the Gaussian distribution", *Physics Letters A* 161: 441.

Puente, C. E. (1996) "A new approach to hydrologic modeling: derived distributions revisited", *Journal of Hydrology* 187:65.

Puente, C. E. and N. Obregón (1996) "A deterministic geometric representation of temporal rainfall. Results for a storm in Boston", *Water Resources Research* 32(9): 2825.

Puente C. E., M. M. López, J. E. Pinzón and J. M. Angulo (1996) "The Gaussian distribution revisited", *Advances in Applied Probability* 28(2): 500.

Puente, C. E. (2003) *Treasures Inside the Bell. Hidden order in chance*. World Scientific.

Puente, C. E. (2006) "Lessons from complexity. The hypotenuse: the pathway of peace", *E:CO, Emergence, Complexity and Organization* 8(2): 96.

Puente, C. E. (2011a) *The Hypotenuse: An Illustrated Scientific Parable for Turbulent Times*, 2/e. Santito Press.

Puente, C. E. (2011b) *The Fig Tree & The Bell: Chaos, Complexity and Christianity*. Santito Press.

# References

Puente, C. E. (2017) “Una clase inusual sobre ciencia y fe en una universidad secular: Caos, Complejidad y Cristiandad”, *Quaerentibus* 5(8):51, [http://quaerentibus.org/assets/q08\\_una-clase-inusual-sobre-ciencia....pdf](http://quaerentibus.org/assets/q08_una-clase-inusual-sobre-ciencia....pdf)

Puente, C. E. (2018) <https://campanitasdefe.com/2018/02/09/la-mejor-aventura/>

Puente, C. E. (2020a) <https://campanitasdefe.com/2020/05/10/del-lamento-al-baile/>

Puente, C. E. (2020b) “De la ciencia de la complejidad al amor de Jesús”, *Quaerentibus* 8(15):132. [http://quaerentibus.org/assets/q15\\_\\_\\_\\_.pdf](http://quaerentibus.org/assets/q15____.pdf)